



EC风机产品手册

EC Fan Product Catalog

CONTENT

目录

01

公司简介 01
Company Profile

02

产品命名规则 04
Product type Description

03

EC 前倾离心风机 06
EC Forward Centrifugal Fan

04

EC 后倾离心风机 15
EC Backward Centrifugal Fan

05

EC 轴流风机 31
EC Axial Fan

06

接线图及端子功能说明 42
Connection Diagram and
Terminal Function Description

07

风机选型 48
Fan Check List

ABOUT ATB

关于 ATB

ATB 于 1919 年由 Gottlob Bauknecht 先生在德国斯图加特附近建立，ATB 是由德文驱动技术 (Antriebstechnik) 及创始人姓 (Bauknecht) 的首字母共同组成。21 世纪初 ATB 已发展成为欧洲第三大电机制造和销售集团，是工业和家用电驱系统领域全球领先的供应商之一。ATB 的产品范围非常广泛，电机和风机都有所涉及，电机从 25W 到 25MW 的产品一应俱全，包括标准解决方案、定制解决方案和设计到订单解决方案（包括为广泛的应用提供完整的驱动系统）。

ATB 于 2011 年加入卧龙集团，目前全球拥有 9 个生产基地，分别位于英国诺维奇，德国诺登汉姆、门兴格拉德巴赫、维尔茨海姆，塞尔维亚，波兰塔尔努夫，中国浙江上虞、湖北武汉和河南南阳，总员工人数超过 3500 人。卧龙作为母公司持有 ATB 绝大部分的股权，ATB 下属各工厂及品牌已完全融入卧龙集团。卧龙控股集团有限公司作为全球电机及驱控领域的领军企业，顺应绿色发展趋势，构建了以智能制造、解决方案为主，涵盖工业互联网、工业自动化、能源管理、房地产、矿业、贸易等多板块业务。

EC 风机由高性能空气动力学叶轮、高效永磁同步电机本体、驱动控制器三部分组成，适用性广，通用程度高，可以通过数字化技术实现智能控制、群控互联、全生命周期管理等，拥有长寿命和高可靠性；并以系统高效节能技术，助力“碳达峰”和“碳中和”，创造更大的社会效益，顺应时代发展的趋势。

Founded in 1919 by Mr. Gottlob Bauknecht near Stuttgart, Germany, ATB is a combination of the German drive technology (Antriebstechnik) and the initials of the founder's surname (Bauknecht). At the beginning of the 21st century, ATB had grown into the third largest motor manufacturing and sales group in Europe and it is one of the world's leading suppliers of industrial and household electric drive systems. ATB's product range is very wide, both motor and fan are involved, motors from 25W to 25MW products are all available, including standard solutions, ODM solutions, and design-to-order solutions (including complete drive systems for a wide range of applications).

ATB, which joined in Wolong Group in 2011, has nine manufacturing sites worldwide, including Norwich, Nordenham, Mönchengladbach, Welzheim, Serbia, tarnów of Poland, Shangyu District of Zhejiang Province, Wuhan of Hubei Province and Nanyang of Henan province of China, with a total of more than 3,500 employees.

Wolong as the parent company holds most of the shares of ATB, ATB affiliated factories and brands have been fully integrated into the Wolong Group. Wolong Holding Group Co., Ltd., as a global leader in the field of motor and drive control enterprises, in line with the trend of green development, to build an intelligent manufacturing, solutions-based, covers Industrial Internet, industrial automation, energy management, real estate, mining, trade and other multi-plate business.

The EC fan consists of a high performance aerodynamics impeller, a high efficiency permanent magnet synchronous motor and a drive controller, it can realize intelligent control, Group Control Interconnection, life cycle management and so on through digital technology, and has long life and high reliability, help "Carbon peak" and "Carbon neutrality" to create greater social benefits, in line with the trend of development of the times.

WOLONG GROUP

1984
公司成立 Founded

18000
员工 Employees

358 亿元
总资产 Total assets

5
研发中心 R & D Center

430 亿元
2021 年销售 2021 sales

39
全球制造工厂
Global Manufacturing Facility



COMPANY INTRODUCTION

公司介绍



公司全景图
Company panorama



车间产线局部图
Production line



风量测试数据采集系统
Fan performance test data acquisition system



风机噪声测试消音室
Fan noise test anechoic chamber



3D 打印机
3D printer

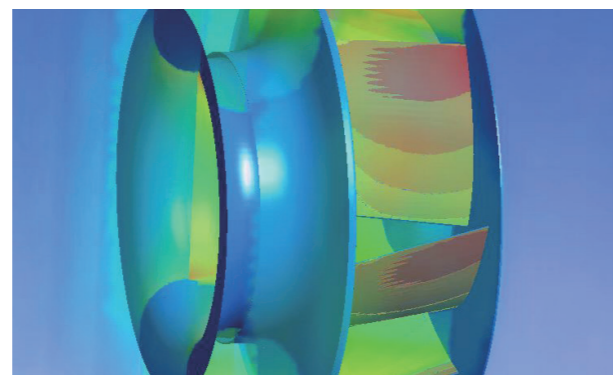

流体仿真分析
Fluid Simulation Analysis

PRODUCT TYPE DESCRIPTION

产品风机命名规则

EC fan Naming Rules

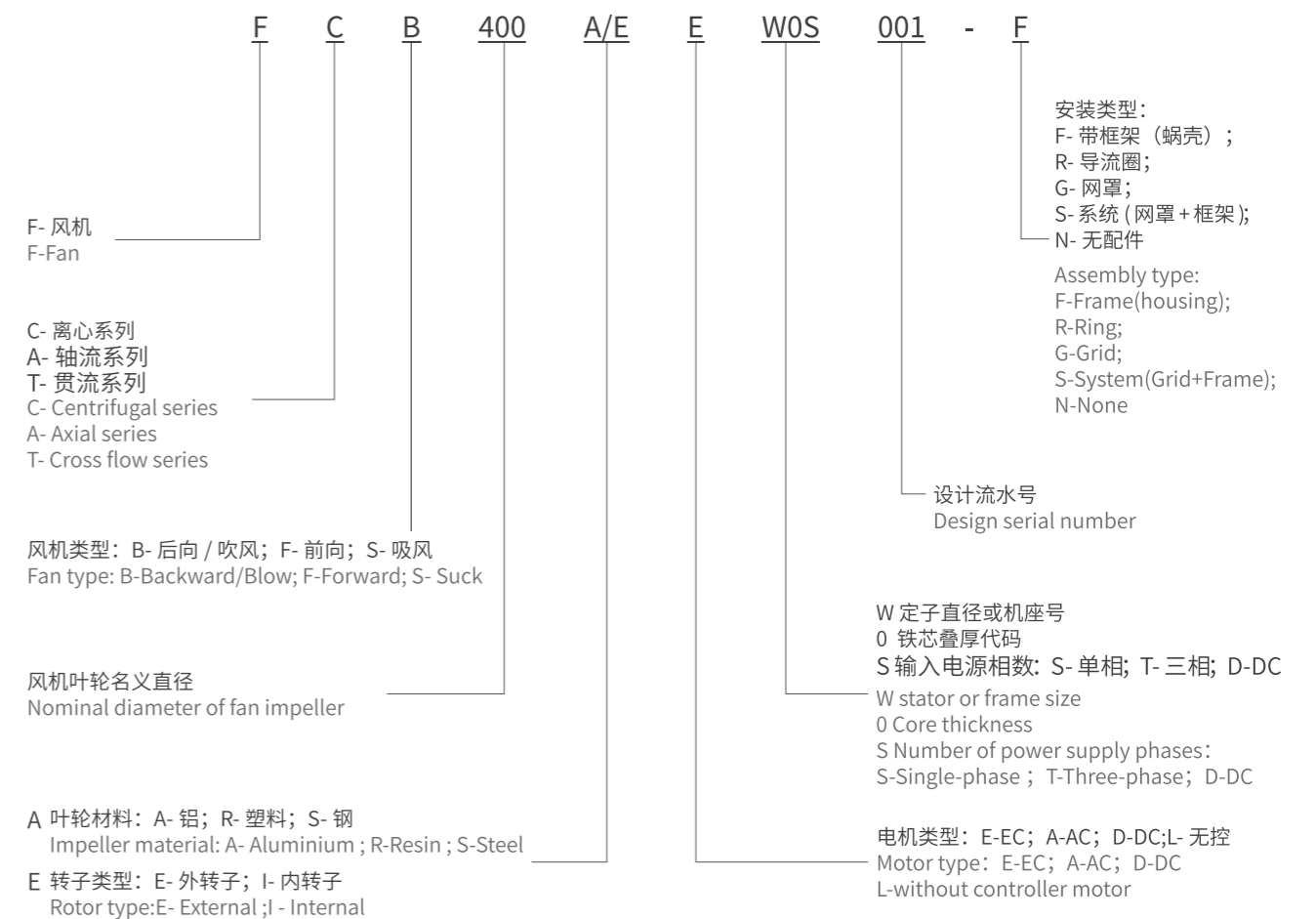

定子直径或机座号代号 W stator or frame size						
外转子 External rotor	U 059	V 074	W 084	X 114	Y 156	Z 200
内转子 Internal rotor	A EM42	B EM48	C EM56	D EM112	E EM132	F EM160

EC FORWARD CENTRIFUGAL FAN

EC 前倾离心风机



EC EXTERNAL ROTOR CENTRIFUGAL FAN FORWARD 133 SINGLE INLET

EC 外转子离心风机 前倾 133 单进风

叶轮材料: 镀锌板	Impeller Material: Galvanized sheet
防护等级: IP44	Protection class: IP44
认证: CCC CE	Approvals: CCC CE
绝缘等级: F	Insulation class: F
调速方式: Vsp/PWM	Speed regulation mode: Vsp/PWM

技术参数 Specification

型号 Type	额定电压 Nominal voltage	频率 Frequency	转速 Speed	额定功率 Rated Power	电流 Current	噪音 LpA	使用温度 Perm.amb.temp.
FCF133S/ EEU0S***-F	[VAC]	[Hz]	[rpm]	[W]	[A]	[dB(A)]	[°C]
	1~200-240	50/60	2000	70	0.55	63	-20°C ~+60°C

P-Q 曲线 P-Q Curves

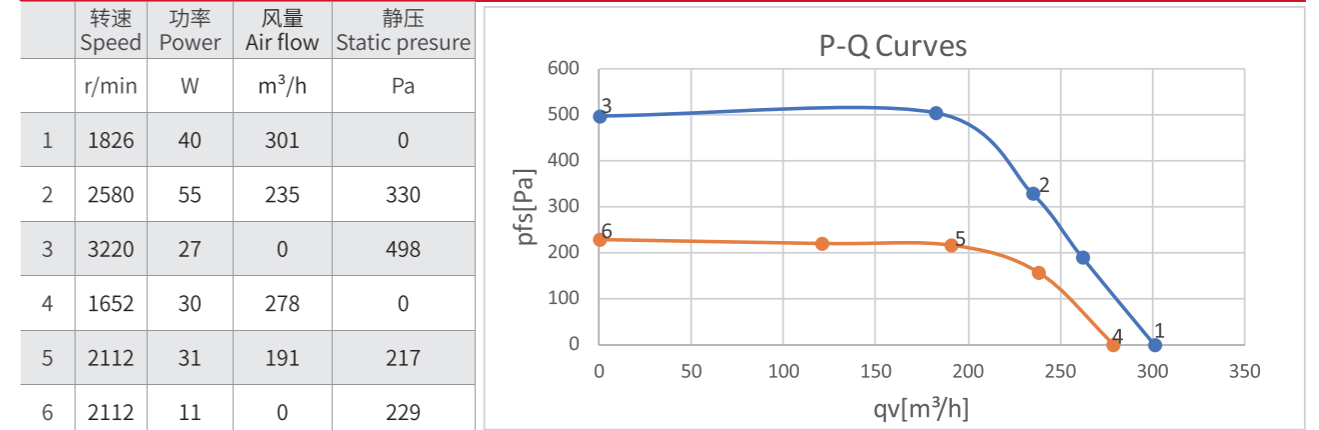

外形尺寸 Dimensions

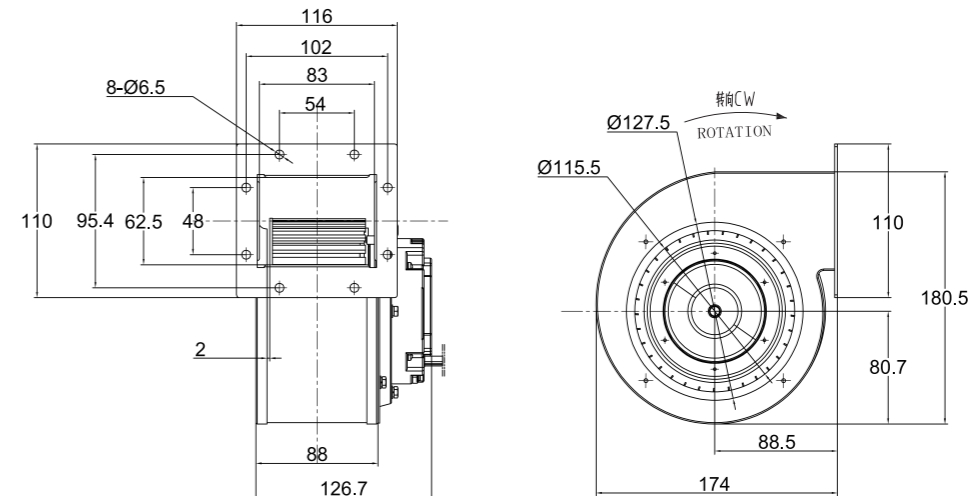



EC EXTERNAL ROTOR CENTRIFUGAL FAN FORWARD 140 SINGLE INLET

EC 外转子离心风机 前倾 140 单进风

叶轮材料: 镀锌板	Impeller Material: Galvanized sheet
防护等级: IP44	Protection class: IP44
认证: CCC CE	Approvals: CCC CE
绝缘等级: F	Insulation class: F
调速方式: Vsp/PWM	Speed regulation mode: Vsp/PWM

技术参数 Specification

型号 Type	额定电压 Nominal voltage	频率 Frequency	转速 Speed	额定功率 Rated Power	电流 Current	噪音 LpA	使用温度 Perm.amb.temp.
FCF140S/ EEU0S***-F	[VAC]	[Hz]	[rpm]	[W]	[A]	[dB(A)]	[°C]
	1~ 200-240	50/60	1800	100	0.8	60	-20°C ~+60°C

P-Q 曲线 P-Q Curves

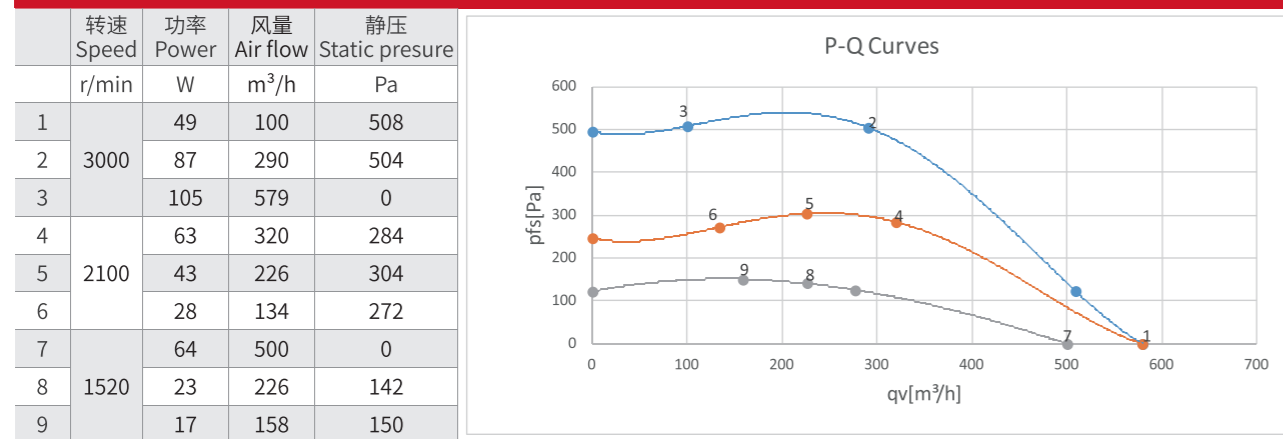

外形尺寸 Dimensions

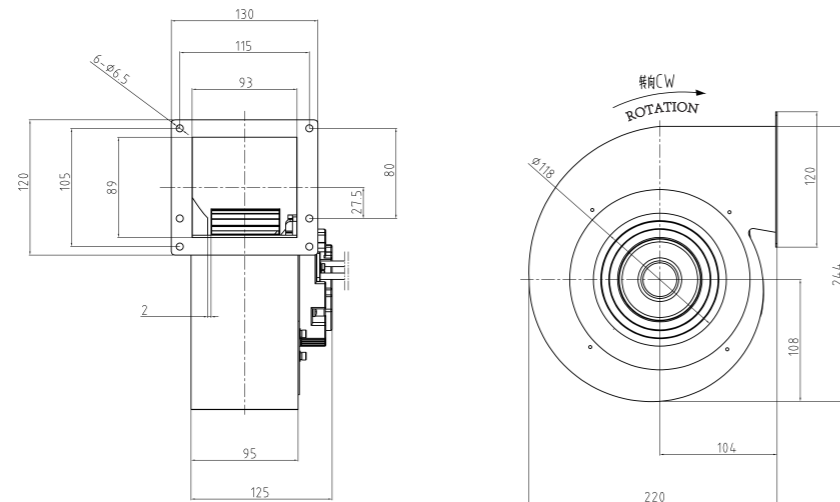

EC EXTERNAL ROTOR CENTRIFUGAL FAN FORWARD 160 SINGLE INLET

EC 外转子离心风机 前倾 160 单进风

叶轮材料: 镀锌板	Impeller Material: Galvanized sheet
防护等级: IP44	Protection class: IP44
认证: CCC CE	Approvals: CCC CE
绝缘等级: F	Insulation class: F
调速方式: Vsp/PWM	Speed regulation mode: Vsp/PWM

技术参数 Specification

型号 Type	额定电压 Nominal voltage	频率 Frequency	转速 Speed	额定功率 Rated Power	电流 Current	噪音 LpA	使用温度 Perm.amb.temp.
FCF160S/ EEU0S***-F	[VAC]	[Hz]	[rpm]	[W]	[A]	[dB(A)]	[°C]
	1~ 200-240	50/60	1700	130	1.0	62	-20°C ~+60°C

P-Q 曲线 P-Q Curves

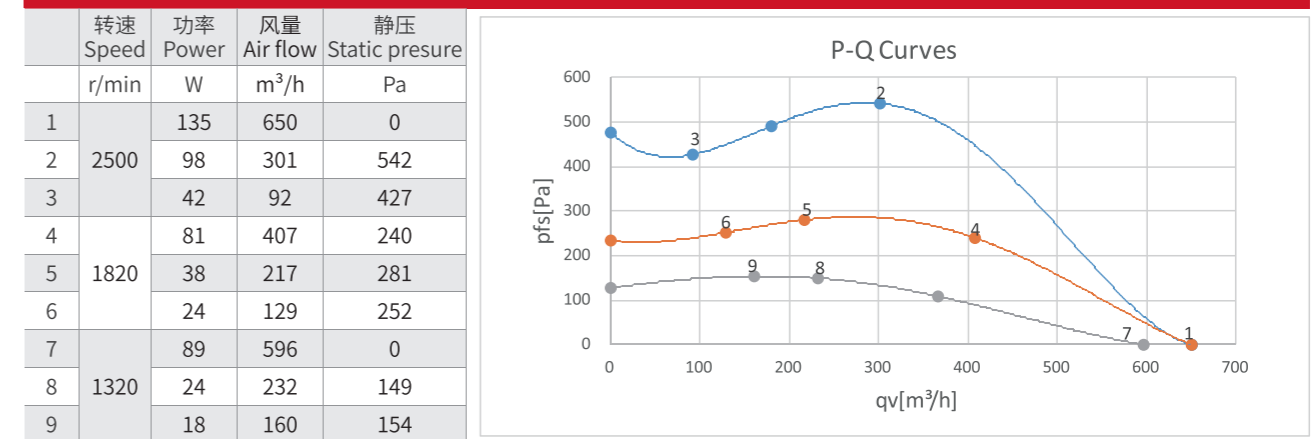

外形尺寸 Dimensions

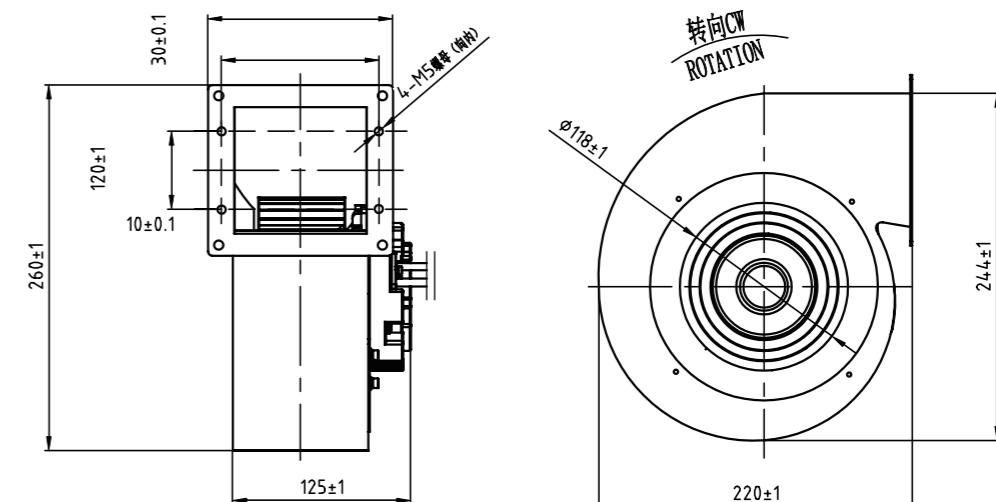



EC EXTERNAL ROTOR CENTRIFUGAL FAN FORWARD 180 SINGLE INLET

EC 外转子离心风机 前倾 180 单进风

叶轮材料: 镀锌板	Impeller Material: Galvanized sheet
防护等级: IP44	Protection class: IP44
认证: CCC CE	Approvals: CCC CE
绝缘等级: F	Insulation class: F
调速方式: Vsp/PWM	Speed regulation mode: Vsp/PWM

技术参数 Specification

型号 Type	额定电压 Nominal voltage	频率 Frequency	转速 Speed	额定功率 Rated Power	电流 Current	噪音 LpA	使用温度 Perm.amb.temp.
FCF180S/ EEV0S***-F	[VAC]	[Hz]	[rpm]	[W]	[A]	[dB(A)]	[°C]
	1~200-240	50/60	1600	180	1.7	69	-20°C ~+60°C

P-Q 曲线 P-Q Curves

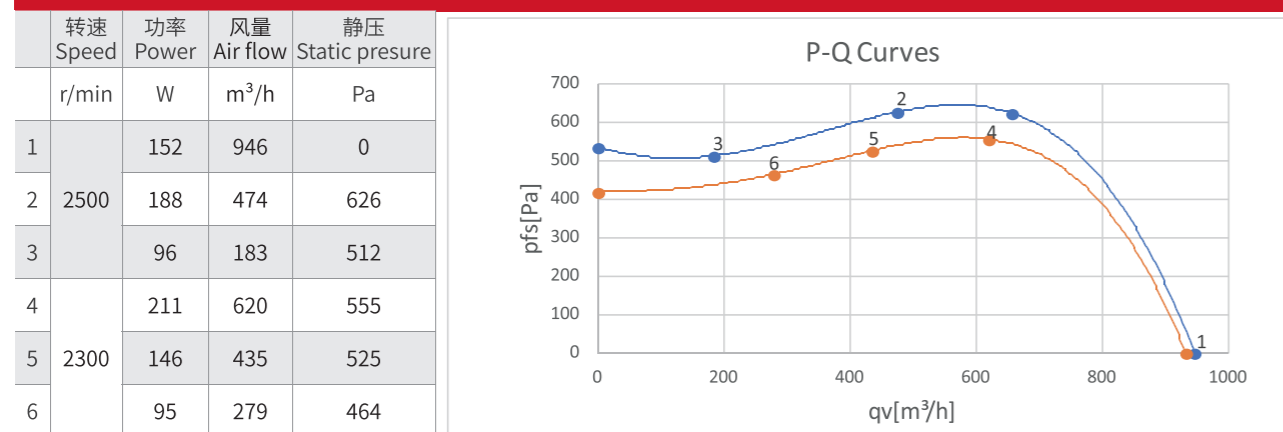

外形尺寸 Dimensions

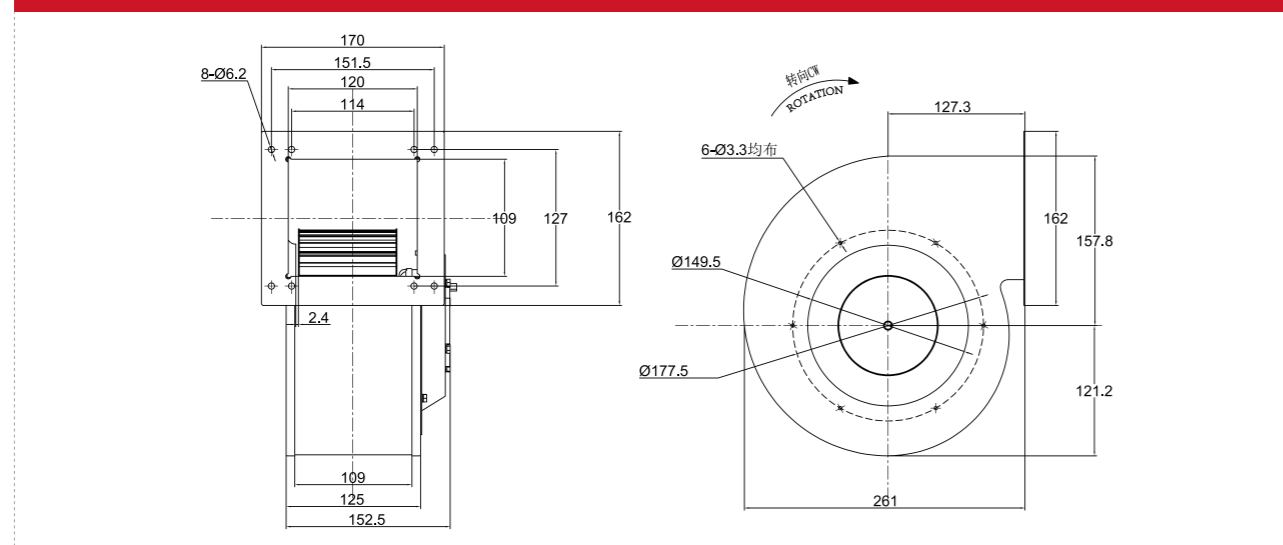

EC INTERNAL ROTOR CENTRIFUGAL FAN FORWARD 8-8 DOUBLE INLET

EC 内转子离心风机 前倾 8-8 双进风

叶轮材料: 镀锌板	Impeller Material: Galvanized sheet
防护等级: IP66	Protection class: IP66
认证: CCC CE	Approvals: CCC CE
绝缘等级: F	Insulation class: F
调速方式: Vsp/PWM/RS485	Speed regulation mode: Vsp/PWM/RS485

技术参数 Specification

型号 Type	额定电压 Nominal voltage	频率 Frequency	转速 Speed	额定功率 Rated Power	电流 Current	噪音 LpA	使用温度 Perm.amb.temp.
FCF8-8S/ IEB0S***-F	[VAC]	[Hz]	[rpm]	[W]	[A]	[dB(A)]	[°C]
	1~115\200-240	50/60	1400	440	3.4	65	-20°C ~+60°C

P-Q 曲线 P-Q Curves

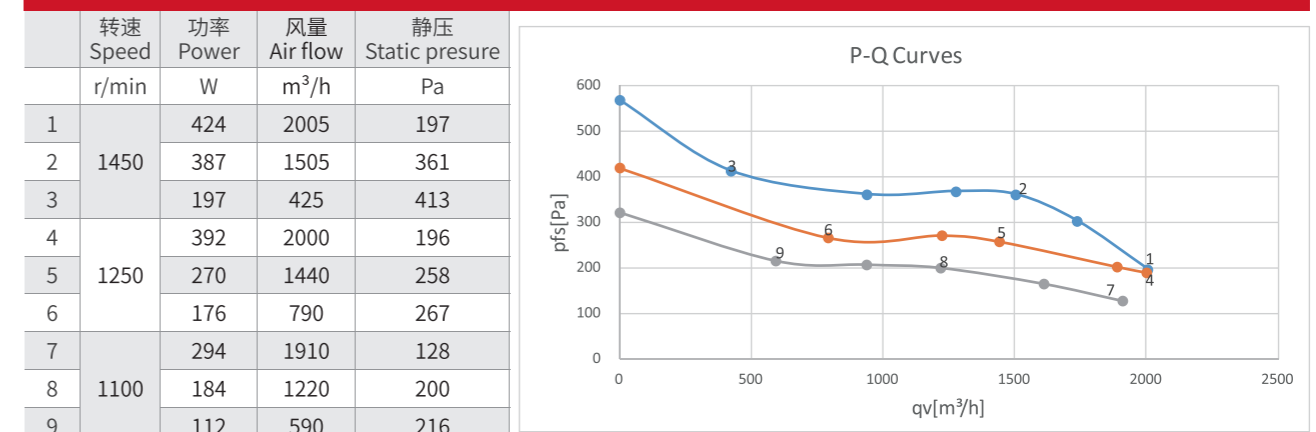

外形尺寸 Dimensions

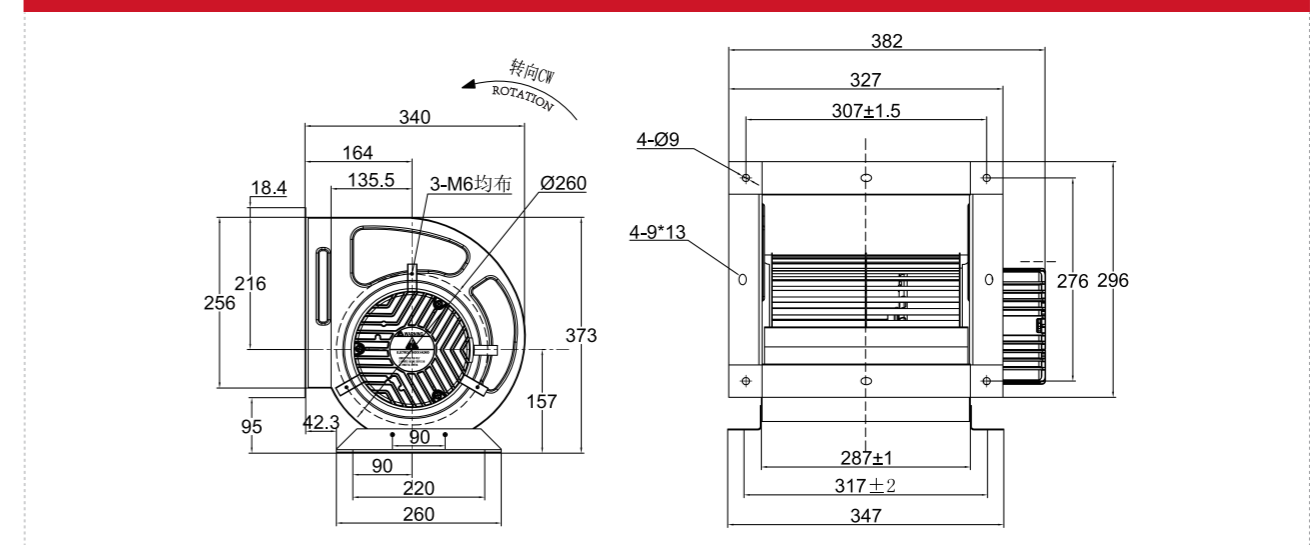



EC INTERNAL ROTOR CENTRIFUGAL FAN FORWARD 9-9 DOUBLE INLET

EC 内转子离心风机 前倾 9-9 双进风

叶轮材料: 镀锌板	Impeller Material: Galvanized sheet
防护等级: IP66	Protection class: IP66
认证: CCC CE	Approvals: CCC CE
绝缘等级: F	Insulation class: F
调速方式: Vsp/PWM/RS485	Speed regulation mode: Vsp/PWM/RS485



EC INTERNAL ROTOR CENTRIFUGAL FAN FORWARD 10-10 DOUBLE INLET

EC 内转子离心风机 前倾 10-10 双进风

叶轮材料: 镀锌板	Impeller Material: Galvanized sheet
防护等级: IP66	Protection class: IP66
认证: CCC CE	Approvals: CCC CE
绝缘等级: F	Insulation class: F
调速方式: Vsp/PWM/RS485	Speed regulation mode: Vsp/PWM/RS485

技术参数 Specification

型号 Type	额定电压 Nominal voltage	频率 Frequency	转速 Speed	额定功率 Rated Power	电流 Current	噪音 LpA	使用温度 Perm.amb.temp.
FCF9-9S/ IEB1S***-F	[VAC] 1~115\200-240	[Hz] 50/60	[rpm] 1400	[W] 620	[A] 4.6	[dB(A)] 65	[°C] -20°C ~+60°C

P-Q 曲线 P-Q Curves

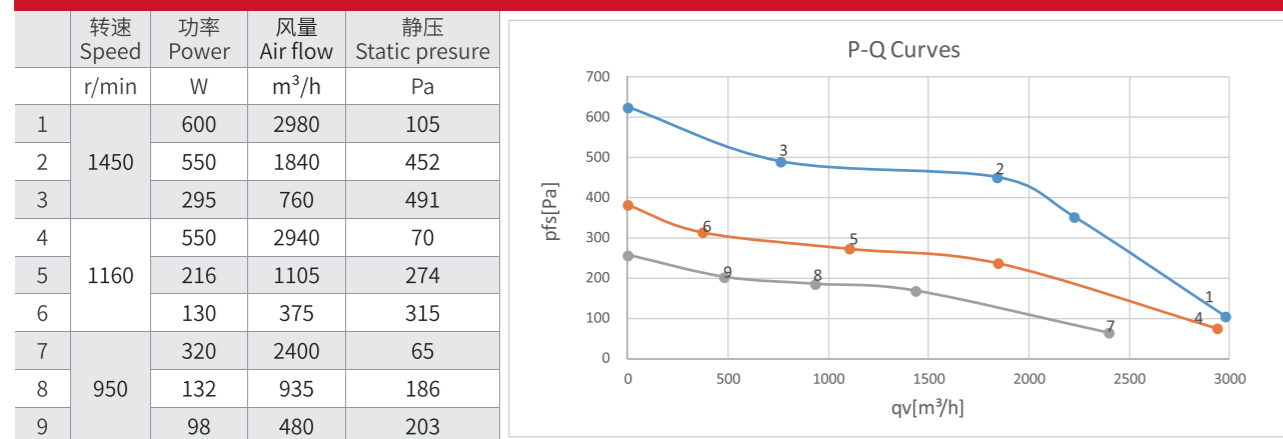

外形尺寸 Dimensions

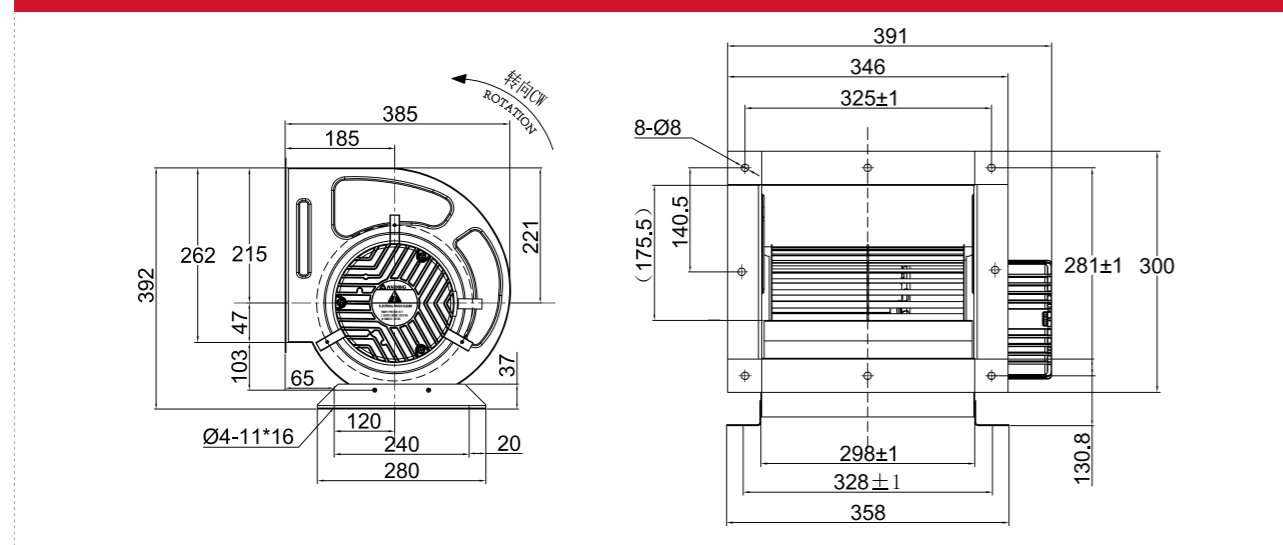

技术参数 Specification

型号 Type	额定电压 Nominal voltage	频率 Frequency	转速 Speed	额定功率 Rated Power	电流 Current	噪音 LpA	使用温度 Perm.amb.temp.
FCF10-10S/ IEB2S***-F	[VAC] 1~115\200-240	[Hz] 50/60	[rpm] 1400	[W] 820	[A] 6	[dB(A)] 65	[°C] -20°C ~+60°C

P-Q 曲线 P-Q Curves

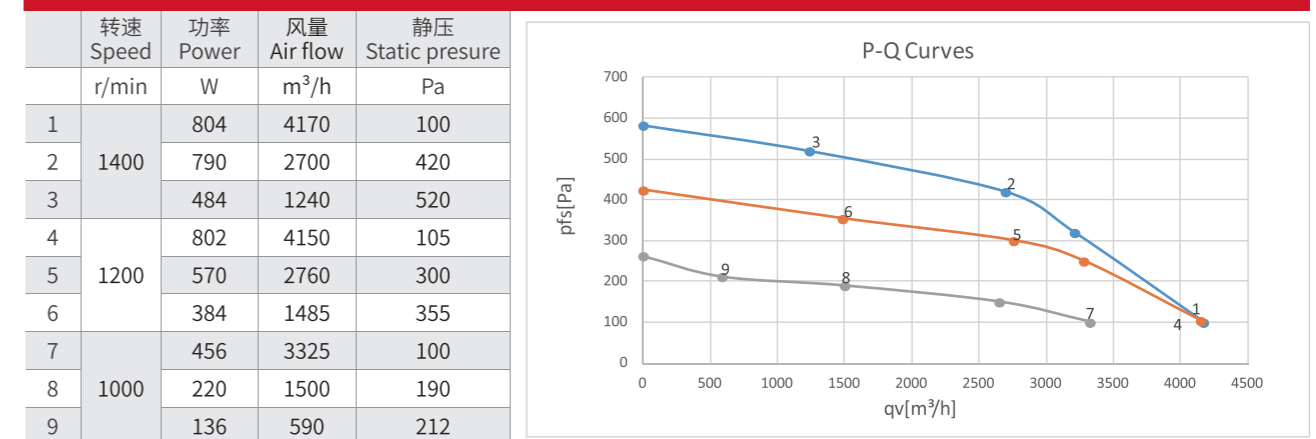

外形尺寸 Dimensions

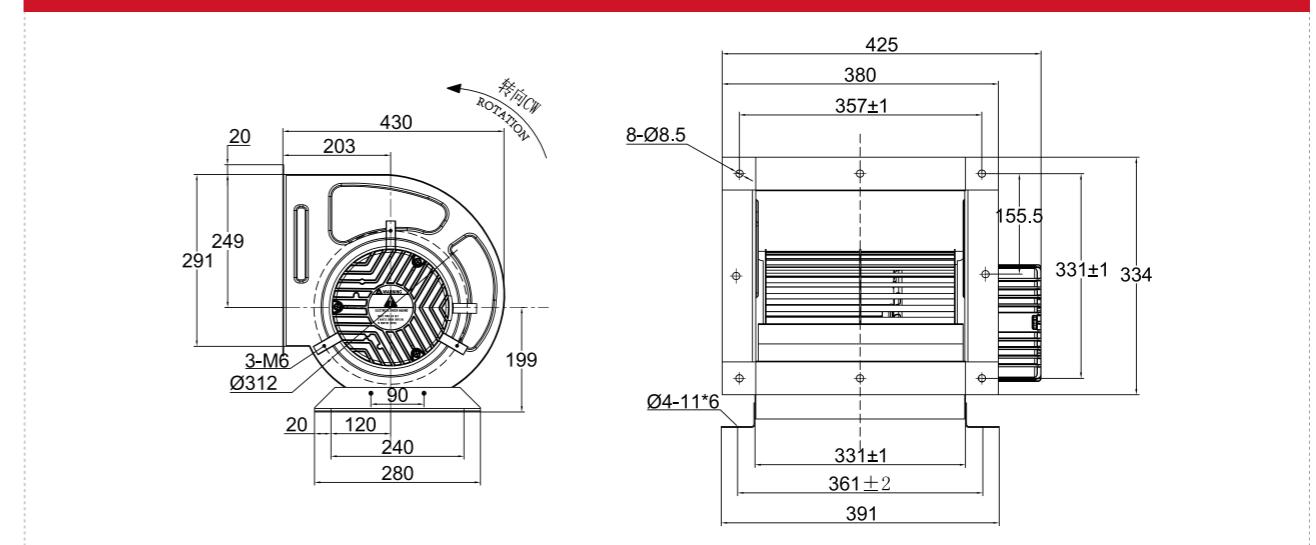

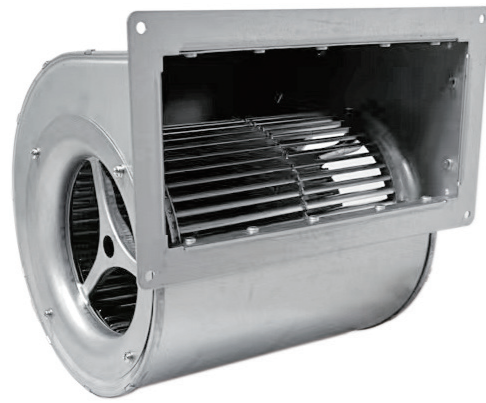

EC EXTERNAL ROTOR CENTRIFUGAL FAN FORWARD 146 DOUBLE INLET

EC 外转子离心风机 前倾 146 双进风

叶轮材料: 镀锌板	Impeller Material: Galvanized sheet
防护等级: IP44	Protection class: IP44
认证: CCC CE	Approvals: CCC CE
绝缘等级: F	Insulation class: F
调速方式: Vsp/PWM	Speed regulation mode: Vsp/PWM

技术参数 Specification

型号 Type	额定电压 Nominal voltage	频率 Frequency	转速 Speed	额定功率 Rated Power	电流 Current	噪音 LpA	使用温度 Perm.amb.temp.
FCF146S/ EEV0S***-F	[VAC]	[Hz]	[rpm]	[W]	[A]	[dB(A)]	[°C]
	1~ 200-240	50/60	2250	240	1.6	65	-20°C ~+60°C

P-Q 曲线 P-Q Curves

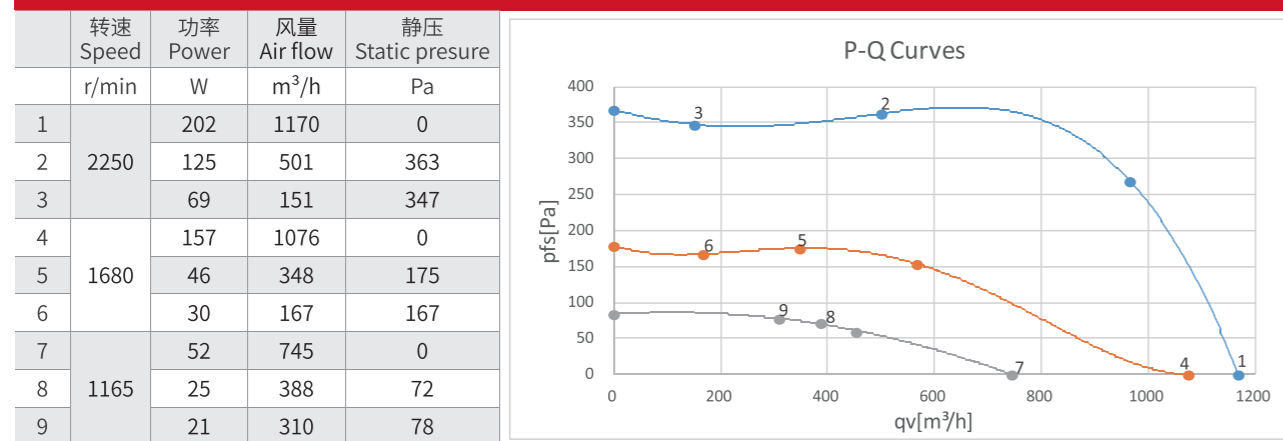

外形尺寸 Dimensions

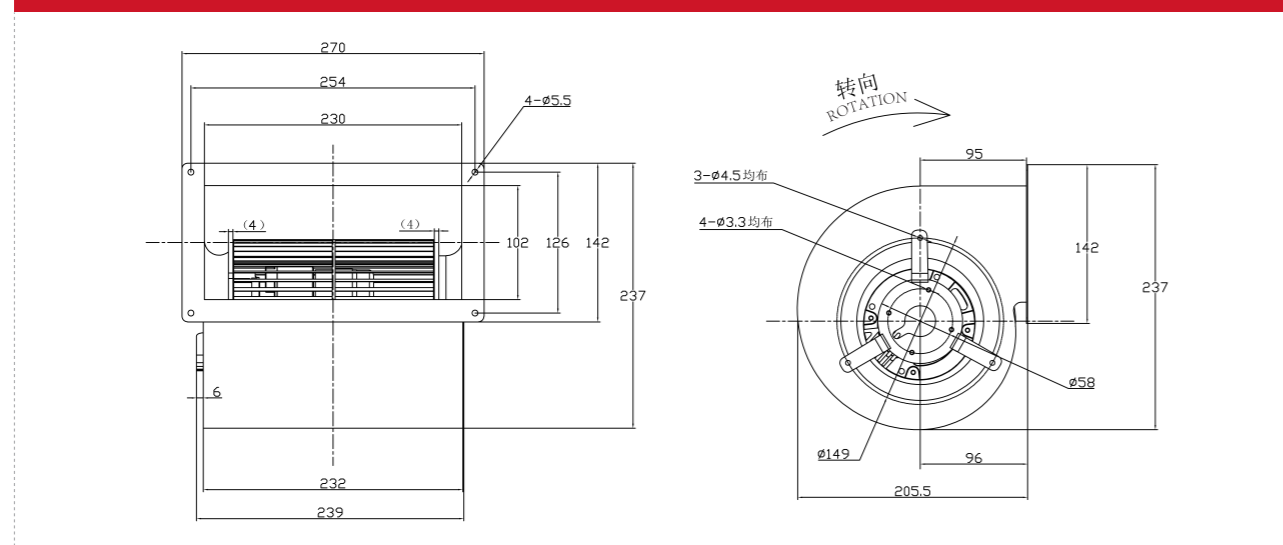

EC BACKWARD CENTRIFUGAL FAN

EC 后倾离心风机





EC EXTERNAL ROTOR CENTRIFUGAL FAN BACKWARD 133

EC 外转子离心风机 后倾 133

叶轮材料: PA6+25%GF	Impeller Material: PA6+25%GF
防护等级: IP44	Protection class: IP44
认证: CCC CE	Approvals: CCC CE
绝缘等级: F	Insulation class: F
调速方式: Vsp/PWM	Speed regulation mode: Vsp/PWM

技术参数 Specification

型号 Type	额定电压 Nominal voltage	频率 Frequency	转速 Speed	额定功率 Rated Power	电流 Current	噪音 LpA	使用温度 Perm.amb.temp.
FCB133R/ EEU0S***-R	[VAC]	[Hz]	[rpm]	[W]	[A]	[dB(A)]	[°C]
	1~200-240	50/60	4600	50	0.48	64	-20°C ~+60°C

P-Q 曲线 P-Q Curves

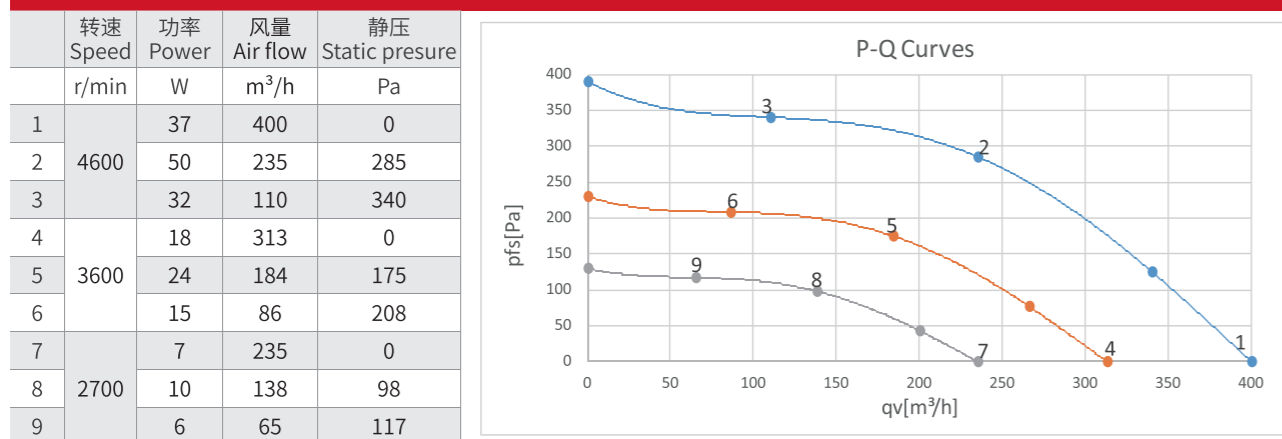

外形尺寸 Dimensions

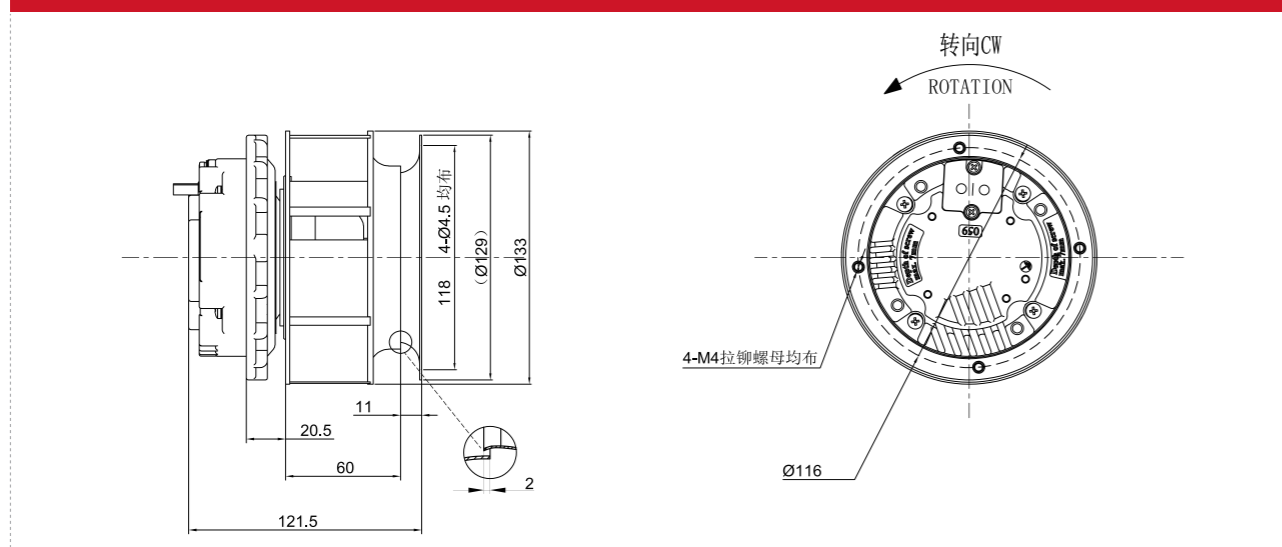

EC EXTERNAL ROTOR CENTRIFUGAL FAN BACKWARD 175

EC 外转子离心风机 后倾 175

叶轮材料: PA6+25%GF	Impeller Material: PA6+25%GF
防护等级: IP44	Protection class: IP44
认证: CCC CE	Approvals: CCC CE
绝缘等级: F	Insulation class: F
调速方式: Vsp/PWM	Speed regulation mode: Vsp/PWM

技术参数 Specification

型号 Type	额定电压 Nominal voltage	频率 Frequency	转速 Speed	额定功率 Rated Power	电流 Current	噪音 LpA	使用温度 Perm.amb.temp.
FCB175R/ EEU0S***-R	[VAC]	[Hz]	[rpm]	[W]	[A]	[dB(A)]	[°C]
	1~200-240	50/60	3240	70	0.6	75	-20°C ~+60°C

P-Q 曲线 P-Q Curves

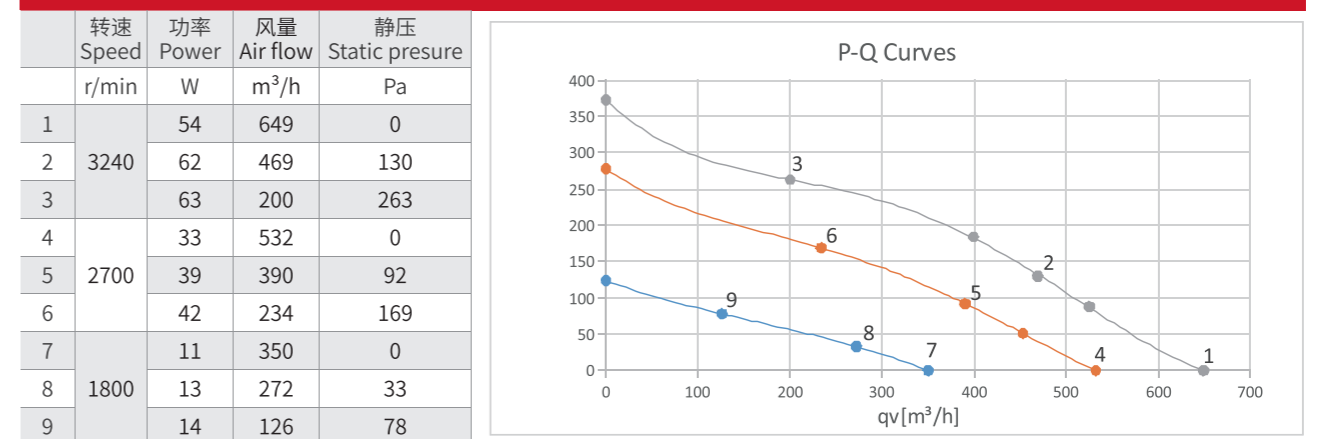

外形尺寸 Dimensions

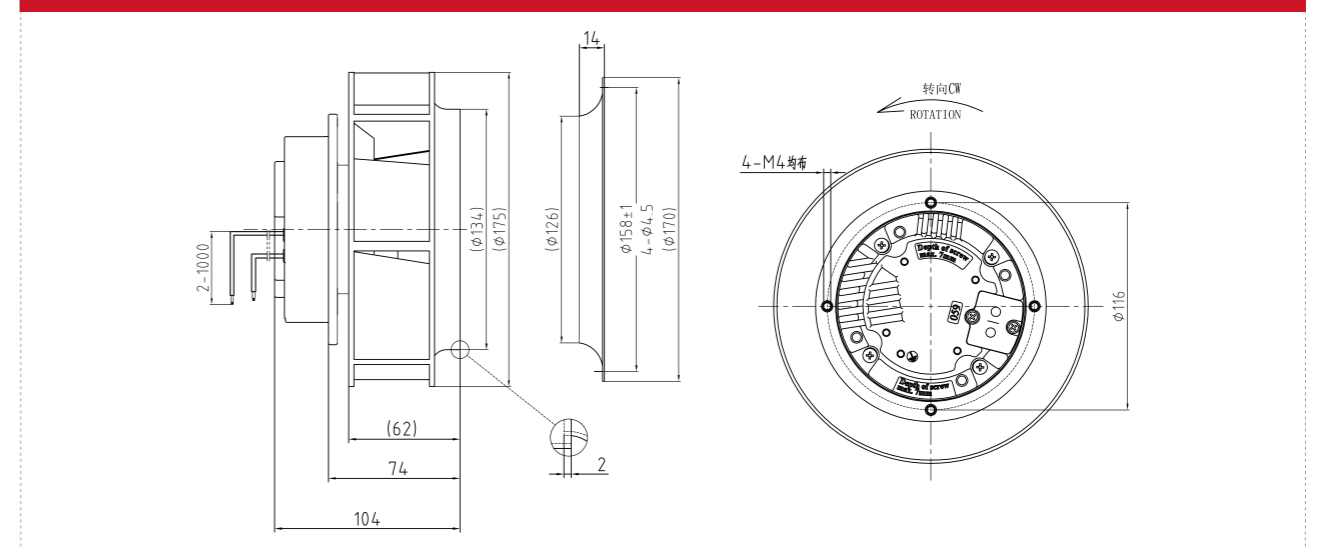



EC EXTERNAL ROTOR CENTRIFUGAL FAN BACKWARD 190

EC 外转子离心风机 后倾 190

叶轮材料: PA6+25%GF	Impeller Material: PA6+25%GF
防护等级: IP44	Protection class: IP44
认证: CCC CE	Approvals: CCC CE
绝缘等级: F	Insulation class: F
调速方式: Vsp/PWM	Speed regulation mode: Vsp/PWM

技术参数 Specification

型号 Type	额定电压 Nominal voltage	频率 Frequency	转速 Speed	额定功率 Rated Power	电流 Current	噪音 LpA	使用温度 Perm.amb.temp.
FCB190R/ EEU0S***-R	[VAC]	[Hz]	[rpm]	[W]	[A]	[dB(A)]	[°C]
	1~200-240	50/60	3240	60	0.5	79	-25°C ~+60°C

P-Q 曲线 P-Q Curves

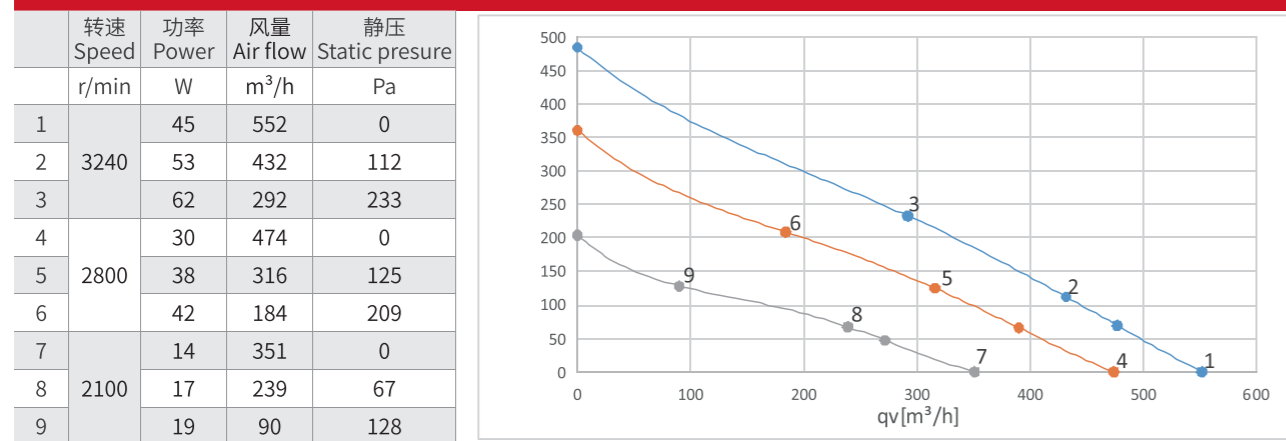

外形尺寸 Dimensions

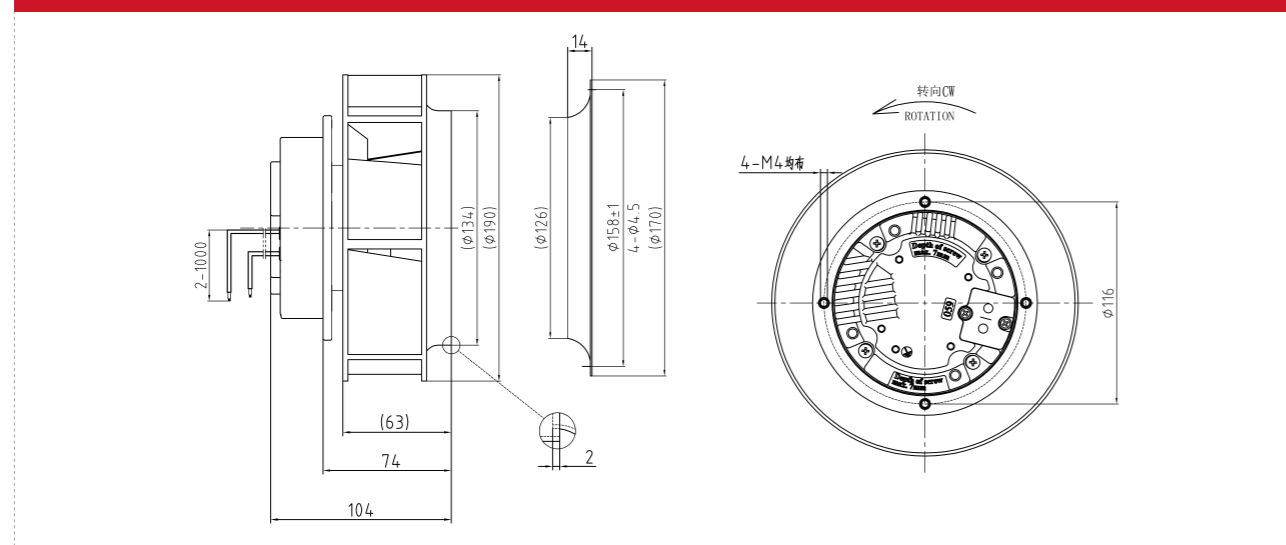

EC EXTERNAL ROTOR CENTRIFUGAL FAN BACKWARD 220

EC 外转子离心风机 后倾 220

叶轮材料: PA6+25%GF	Impeller Material: PA6+25%GF
防护等级: IP44	Protection class: IP44
认证: CCC CE	Approvals: CCC CE
绝缘等级: F	Insulation class: F
调速方式: Vsp/PWM	Speed regulation mode: Vsp/PWM

技术参数 Specification

型号 Type	额定电压 Nominal voltage	频率 Frequency	转速 Speed	额定功率 Rated Power	电流 Current	噪音 LpA	使用温度 Perm.amb.temp.
FCB220R/ EEU0S***-R	[VAC]	[Hz]	[rpm]	[W]	[A]	[dB(A)]	[°C]
	1~200-240	50/60	2600	100	0.6	72	-25°C ~+60°C

P-Q 曲线 P-Q Curves

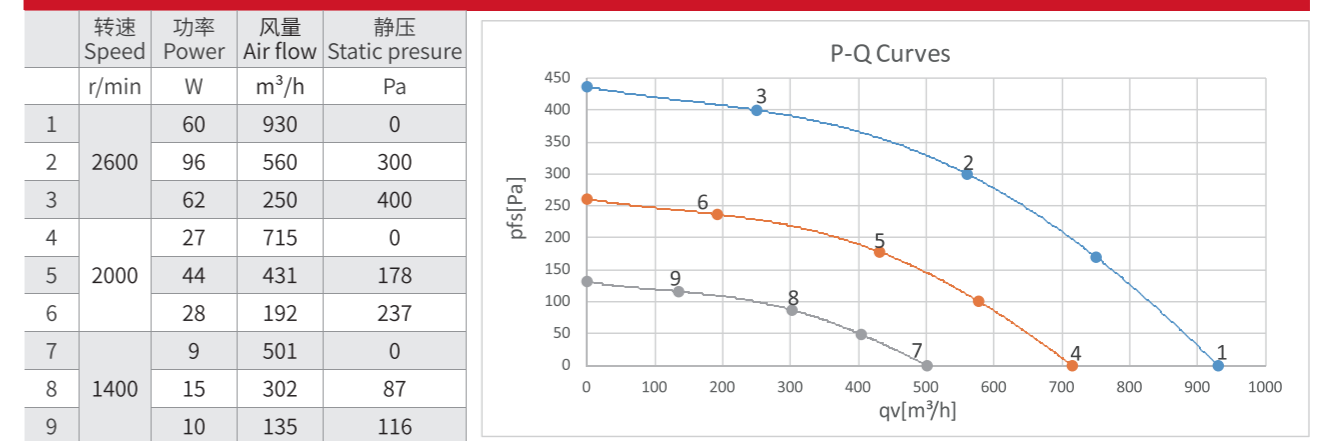

外形尺寸 Dimensions

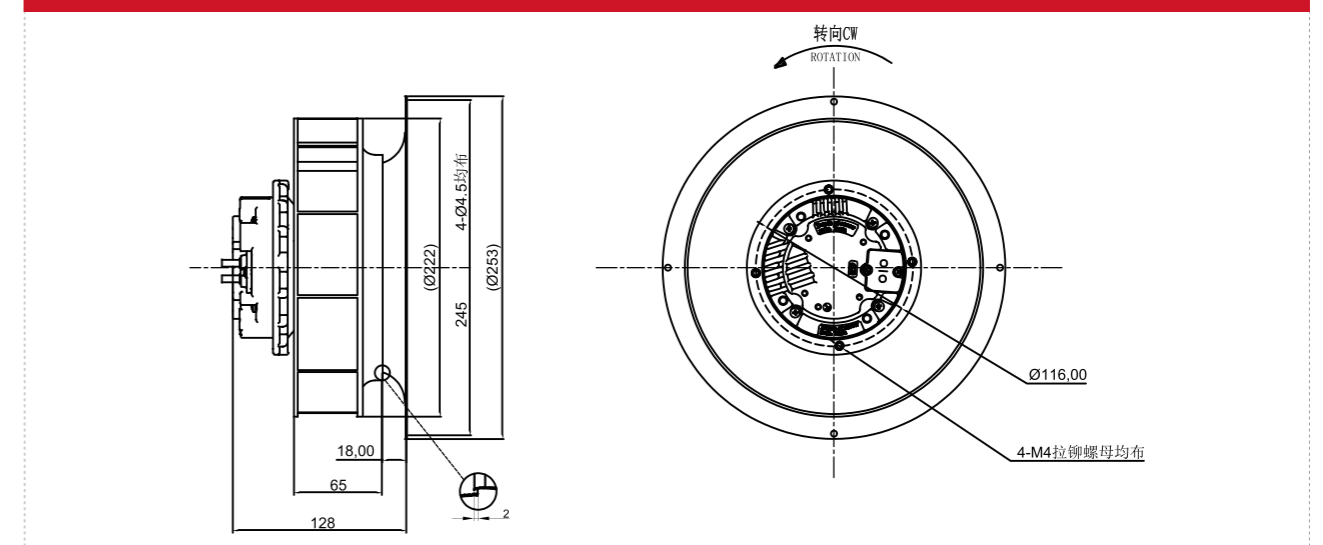



EC EXTERNAL ROTOR CENTRIFUGAL FAN BACKWARD 225

EC 外转子离心风机 后倾 225

叶轮材料: PA6+25%GF	Impeller Material: PA6+25%GF
防护等级: IP44	Protection class: IP44
认证: CCC CE	Approvals: CCC CE
绝缘等级: F	Insulation class: F
调速方式: Vsp/PWM	Speed regulation mode: Vsp/PWM

技术参数 Specification

型号 Type	额定电压 Nominal voltage	频率 Frequency	转速 Speed	额定功率 Rated Power	电流 Current	噪音 LpA	使用温度 Perm.amb.temp.
FCB225R/ EEU0S***-R	[VAC]	[Hz]	[rpm]	[W]	[A]	[dB(A)]	[°C]
	1~ 200-240	50/60	2350	100	0.8	69	-20°C ~+60°C

P-Q 曲线 P-Q Curves

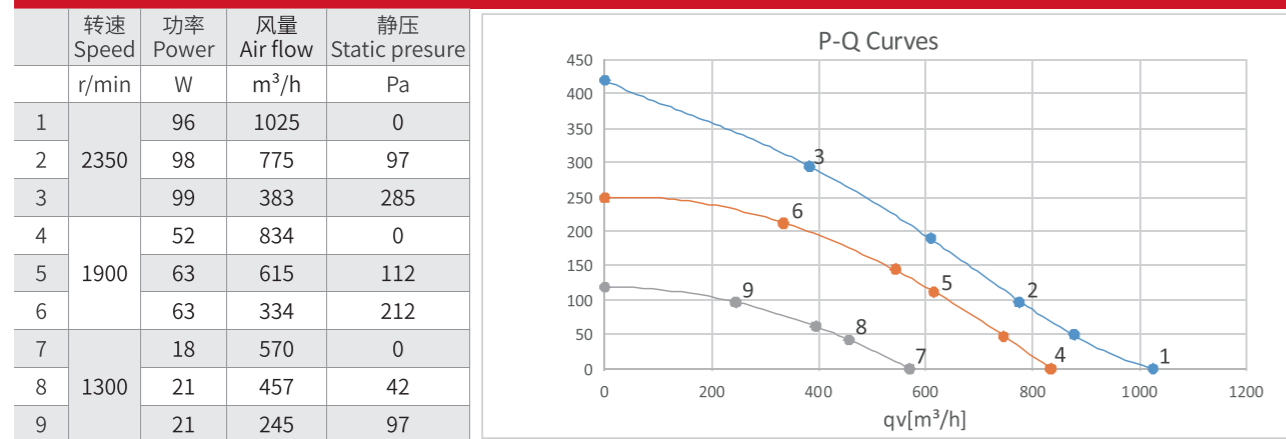

外形尺寸 Dimensions

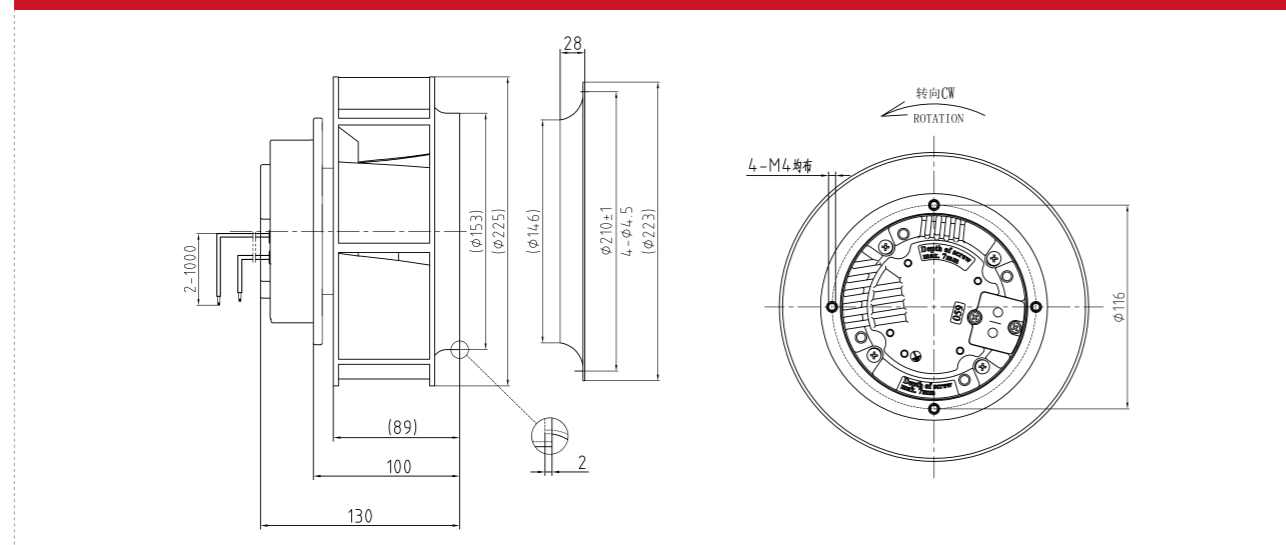

EC EXTERNAL ROTOR CENTRIFUGAL FAN BACKWARD 250

EC 外转子离心风机 后倾 250

叶轮材料: PA6+25%GF	Impeller Material: PA6+25%GF
防护等级: IP44	Protection class: IP44
认证: CCC CE	Approvals: CCC CE
绝缘等级: F	Insulation class: F
调速方式: Vsp/PWM	Speed regulation mode: Vsp/PWM

技术参数 Specification

型号 Type	额定电压 Nominal voltage	频率 Frequency	转速 Speed	额定功率 Rated Power	电流 Current	噪音 LpA	使用温度 Perm.amb.temp.
ECB250R/ EEV0S***-R	[VAC]	[Hz]	[rpm]	[W]	[A]	[dB(A)]	[°C]
	1~ 200-240	50/60	3000	250	1.6	69	-20°C ~+60°C

P-Q 曲线 P-Q Curves

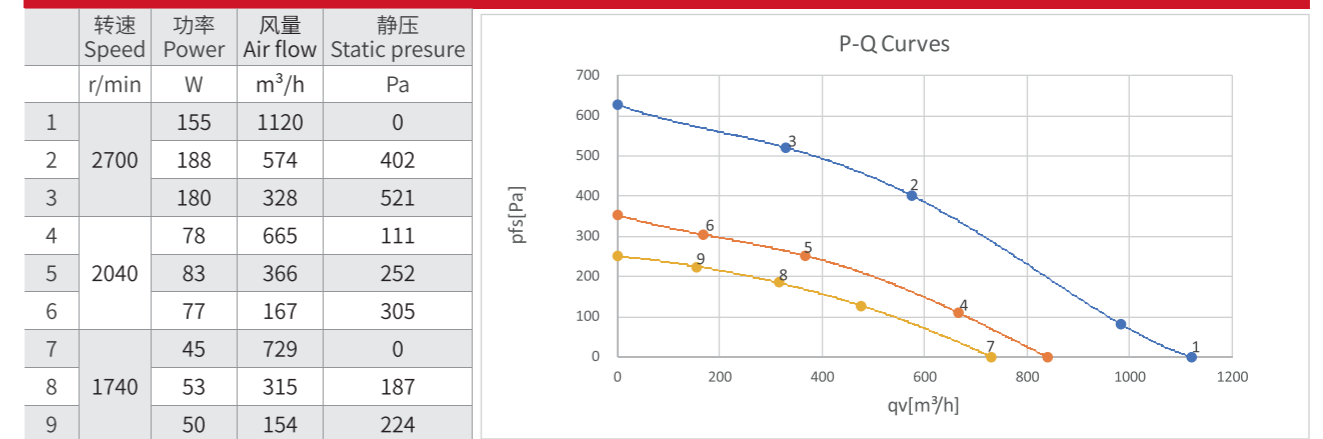

外形尺寸 Dimensions

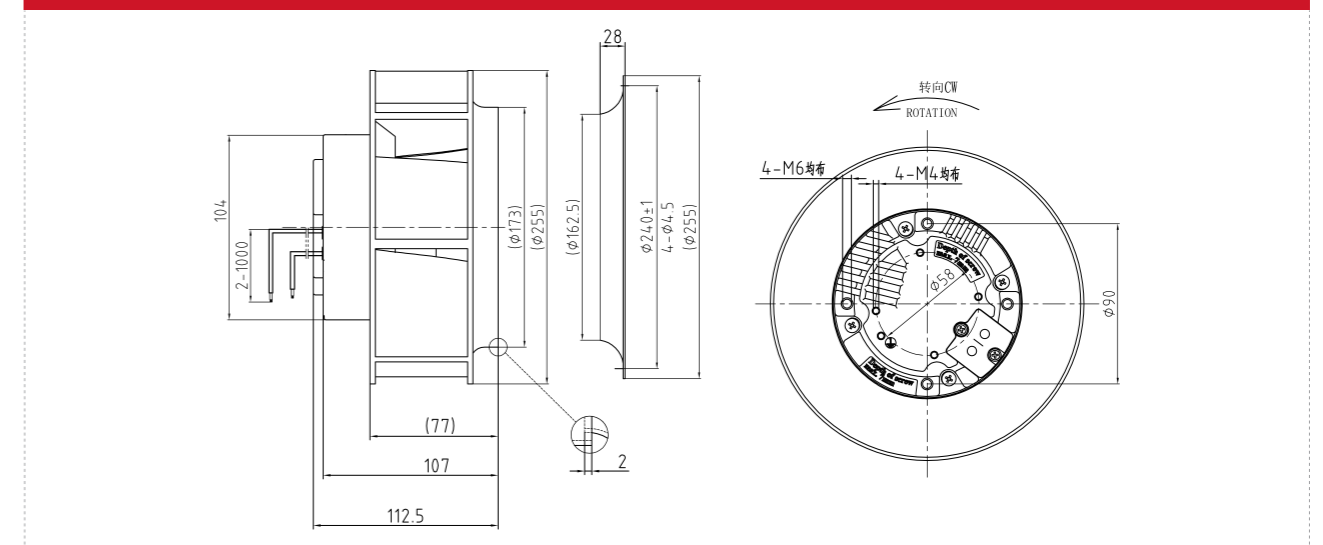



EC EXTERNAL ROTOR CENTRIFUGAL FAN BACKWARD 280

EC 外转子离心风机 后倾 280

叶轮材料: 铝合金	Impeller Material: Sheet aluminium
防护等级: IP44	Protection class: IP44
认证: CCC CE	Approvals: CCC CE
绝缘等级: F	Insulation class: F
调速方式: Vsp/RS485	Speed regulation mode: Vsp/RS485

技术参数 Specification

型号 Type	额定电压 Nominal voltage	频率 Frequency	转速 Speed	额定功率 Rated Power	电流 Current	噪音 LpA	使用温度 Perm.amb.temp.
FCB280A/ EEW0S***-R	[VAC] 1~ 200-277	[Hz] 50/60	[rpm] 2500	[W] 450	[A] 2.0	[dB(A)] 68	[°C] -20°C ~+60°C

P-Q 曲线 P-Q Curves

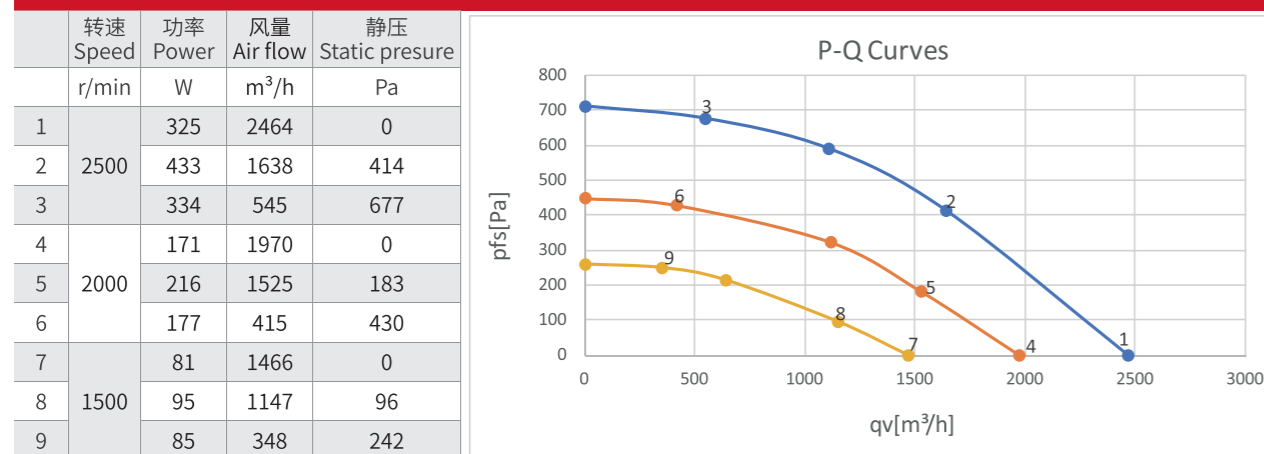

外形尺寸 Dimensions

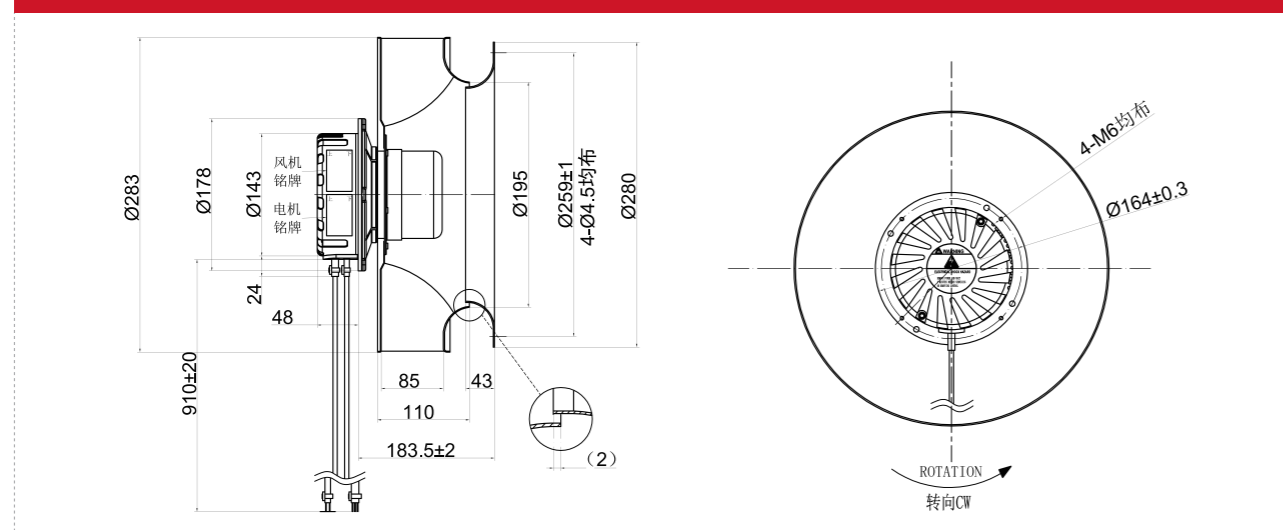

EC EXTERNAL ROTOR CENTRIFUGAL FAN BACKWARD 310

EC 外转子离心风机 后倾 310

叶轮材料: 铝合金	Impeller Material: Sheet aluminium
防护等级: IP44	Protection class: IP44
认证: CCC CE	Approvals: CCC CE
绝缘等级: F	Insulation class: F
调速方式: Vsp/RS485	Speed regulation mode: Vsp/RS485

技术参数 Specification

型号 Type	额定电压 Nominal voltage	频率 Frequency	转速 Speed	额定功率 Rated Power	电流 Current	噪音 LpA	使用温度 Perm.amb.temp.
FCB310A/ EEW0S***-R	[VAC] 1~ 200-277	[Hz] 50/60	[rpm] 2500	[W] 400	[A] 2.1~1.4	[dB(A)] 68	[°C] 0°C ~+40°C

P-Q 曲线 P-Q Curves

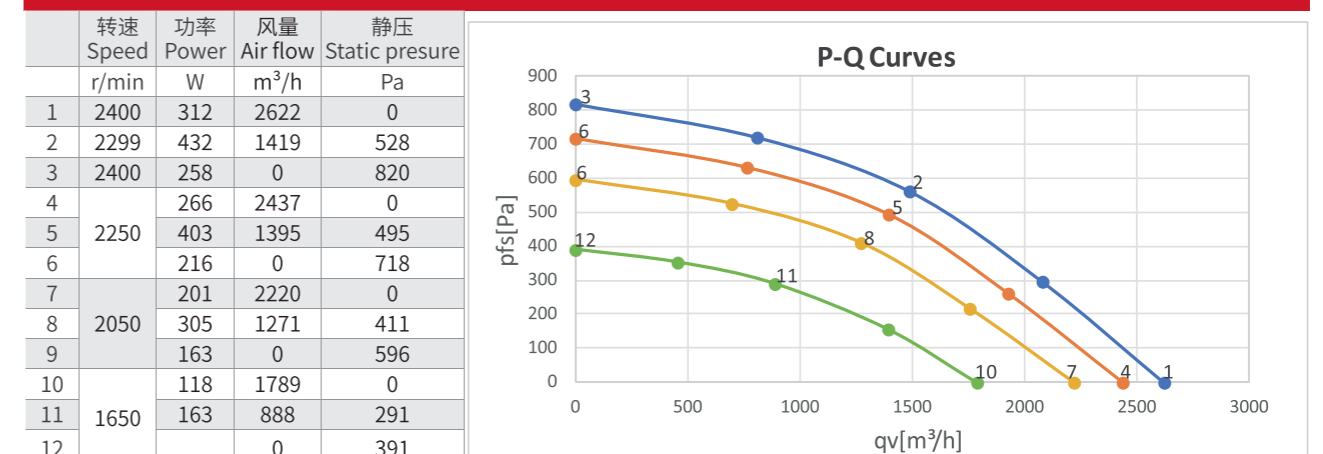

外形尺寸 Dimensions

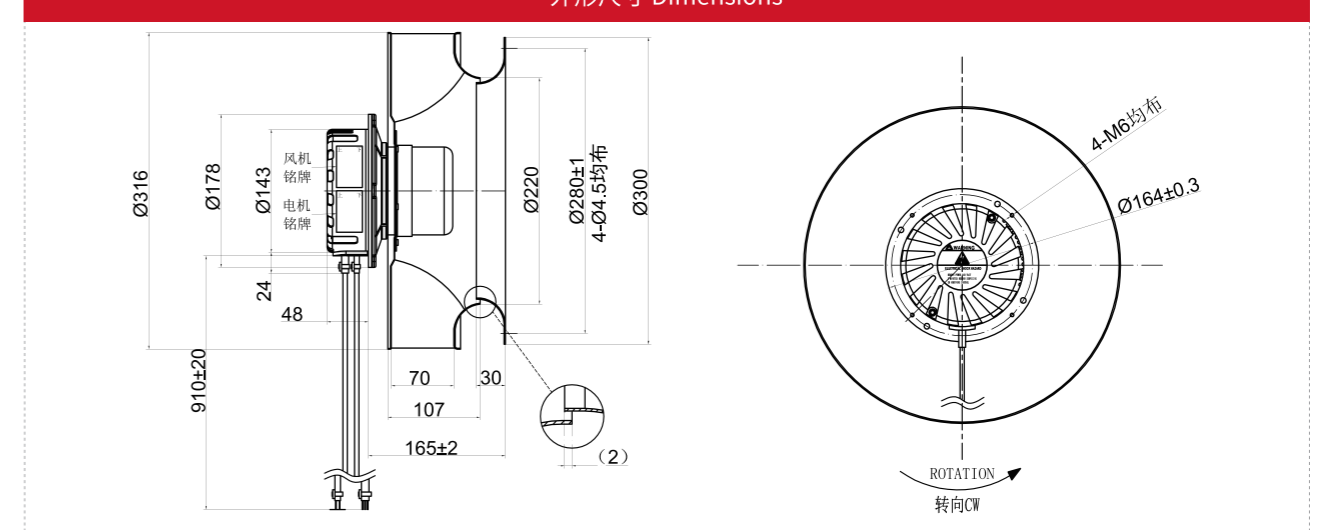



EC EXTERNAL ROTOR CENTRIFUGAL FAN BACKWARD 355

EC 外转子离心风机 后倾 355

叶轮材料: 铝合金	Impeller Material: Sheet aluminium
防护等级: IP44	Protection class: IP44
认证: CCC CE	Approvals: CCC CE
绝缘等级: F	Insulation class: F
调速方式: Vsp/RS485	Speed regulation mode: Vsp/RS485

技术参数 Specification

型号 Type	额定电压 Nominal voltage	频率 Frequency	转速 Speed	额定功率 Rated Power	电流 Current	噪音 LpA	使用温度 Perm.amb.temp.
FCB355A/ EEW0S***-R	[VAC]	[Hz]	[rpm]	[W]	[A]	[dB(A)]	[°C]
	1~200-277	50/60	1930	330	1.44	75	-20°C ~+60°C

P-Q 曲线 P-Q Curves

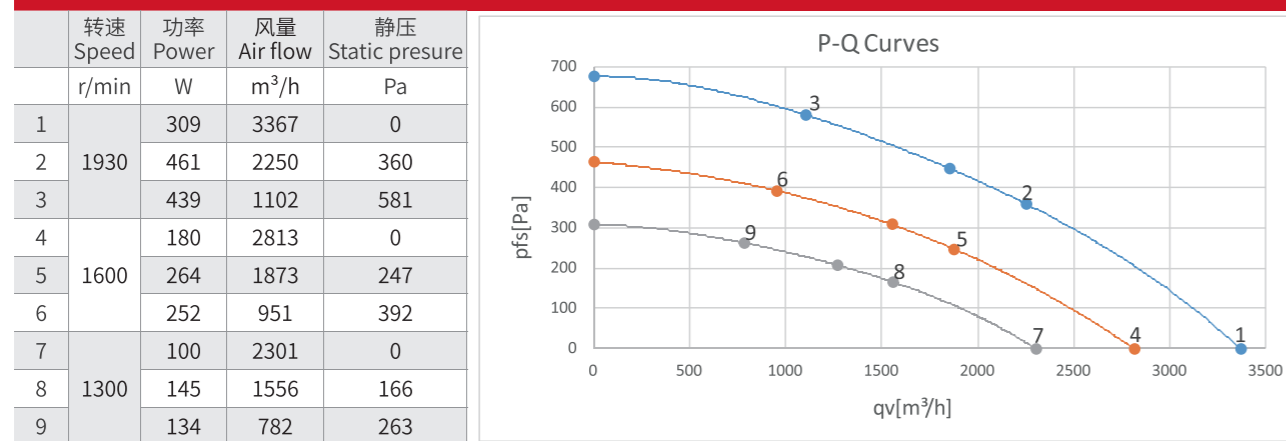

外形尺寸 Dimensions

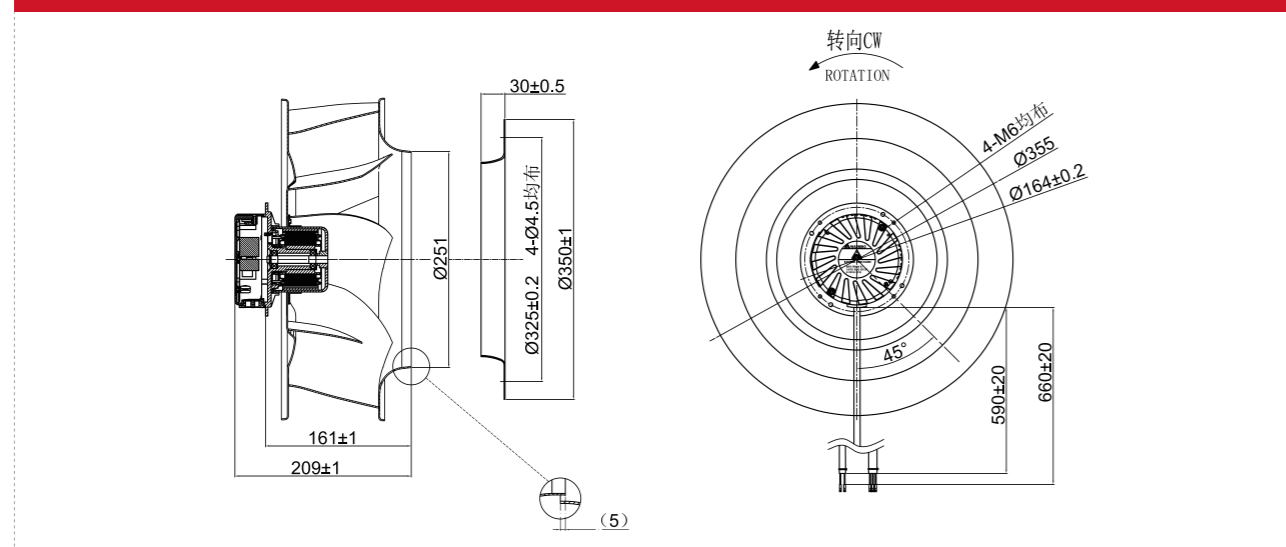

EC EXTERNAL ROTOR CENTRIFUGAL FAN BACKWARD 355

EC 外转子离心风机 后倾 355

叶轮材料: 铝合金	Impeller Material: Sheet aluminium
防护等级: IP55	Protection class: IP55
认证: CCC CE	Approvals: CCC CE
绝缘等级: F	Insulation class: F
调速方式: Vsp/RS485	Speed regulation mode: Vsp/RS485

技术参数 Specification

型号 Type	额定电压 Nominal voltage	频率 Frequency	转速 Speed	额定功率 Rated Power	电流 Current	噪音 LpA	使用温度 Perm.amb.temp.
FCB355A/ EEW0T***-R	[VAC]	[Hz]	[rpm]	[W]	[A]	[dB(A)]	[°C]
	3~380-480	50/60	1700	480	1	75	-20°C ~+60°C

P-Q 曲线 P-Q Curves

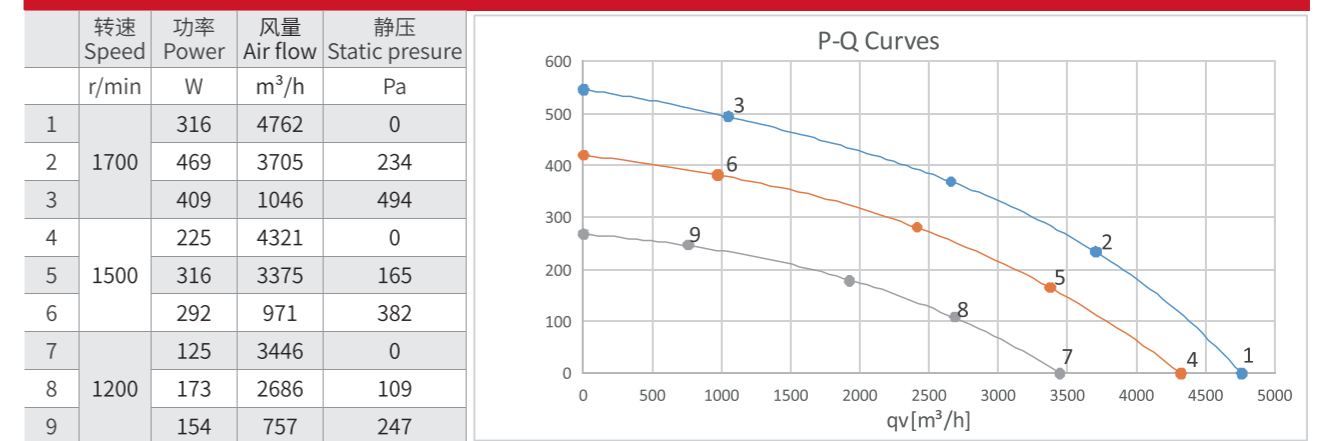

外形尺寸 Dimensions

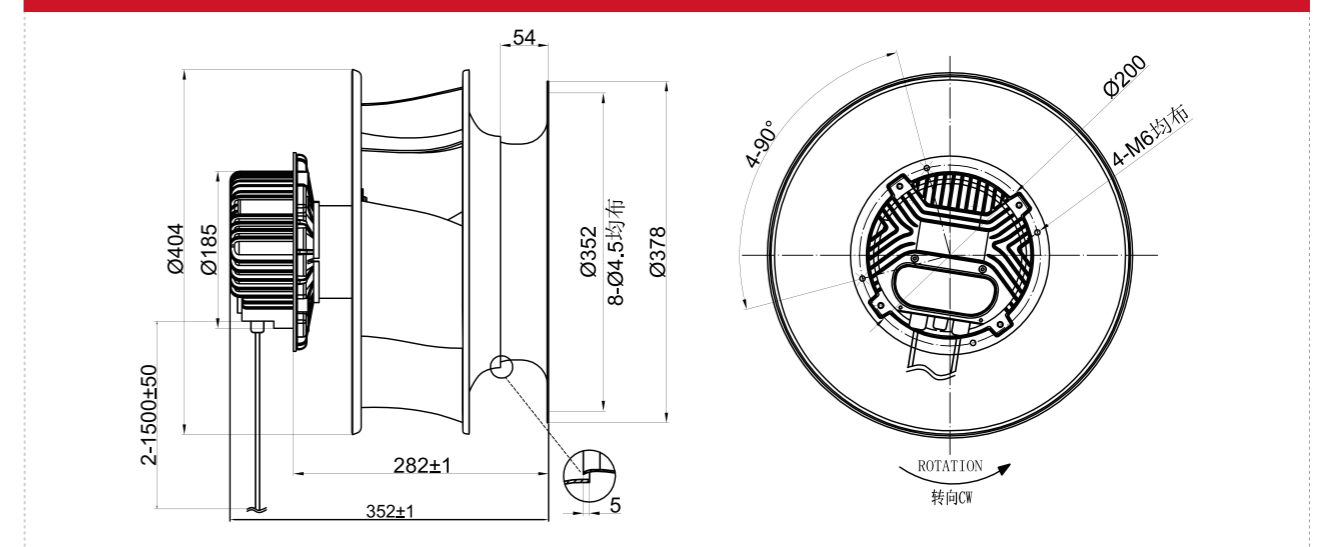



EC EXTERNAL ROTOR CENTRIFUGAL FAN BACKWARD 400

EC 外转子离心风机 后倾 400

叶轮材料: PP+40%GF	Impeller Material: PP+40%GF
防护等级: IP44	Protection class: IP44
认证: CCC CE	Approvals: CCC CE
绝缘等级: F	Insulation class: F
调速方式: Vsp/RS485	Speed regulation mode: Vsp/RS485

技术参数 Specification

型号 Type	额定电压 Nominal voltage	频率 Frequency	转速 Speed	额定功率 Rated Power	电流 Current	噪音 LpA	使用温度 Perm.amb.temp.
FCB400R/ EEW0S***-R	[VAC]	[Hz]	[rpm]	[W]	[A]	[dB(A)]	[°C]
	1~ 200-277	50/60	1500	400	2.1~1.4	72	0°C ~+40°C

P-Q 曲线 P-Q Curves

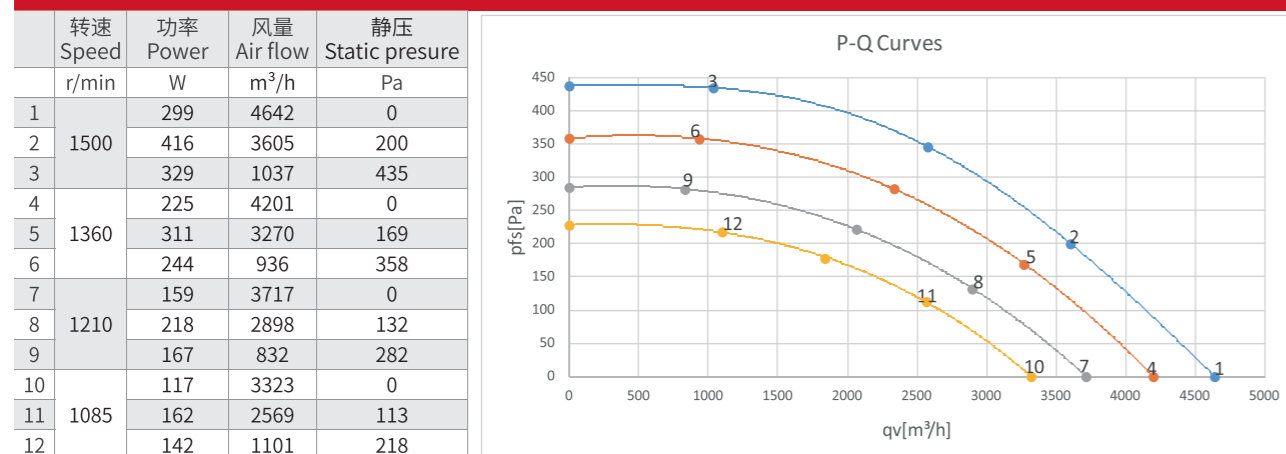

外形尺寸 Dimensions

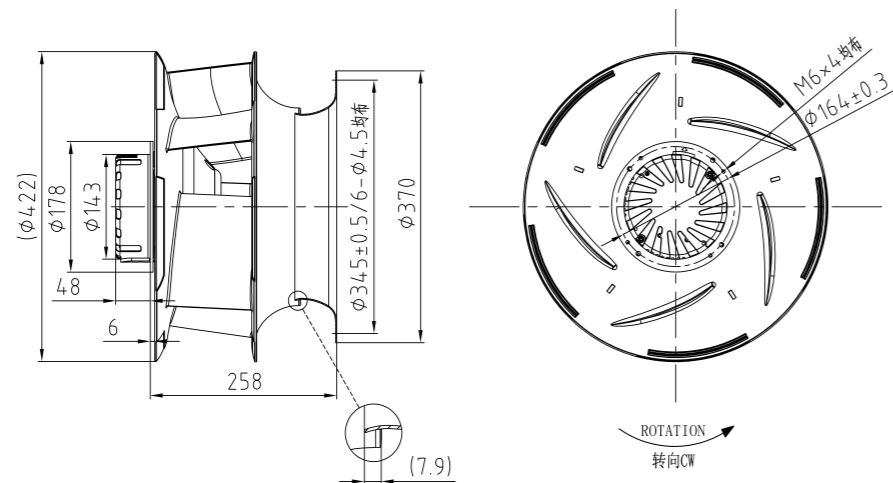

EC EXTERNAL ROTOR CENTRIFUGAL FAN BACKWARD 400

EC 外转子离心风机 后倾 400

叶轮材料: 铝合金	Impeller Material: Sheet aluminium
防护等级: IP44	Protection class: IP44
认证: CCC CE	Approvals: CCC CE
绝缘等级: F	Insulation class: F
调速方式: Vsp/RS485	Speed regulation mode: Vsp/RS485

技术参数 Specification

型号 Type	额定电压 Nominal voltage	频率 Frequency	转速 Speed	额定功率 Rated Power	电流 Current	噪音 LpA	使用温度 Perm.amb.temp.
FCB400A/ EEW0S***-R	[VAC]	[Hz]	[rpm]	[W]	[A]	[dB(A)]	[°C]
	1~ 200-277	50/60	1500	390	1.7	72	-25°C ~+60°C

P-Q 曲线 P-Q Curves

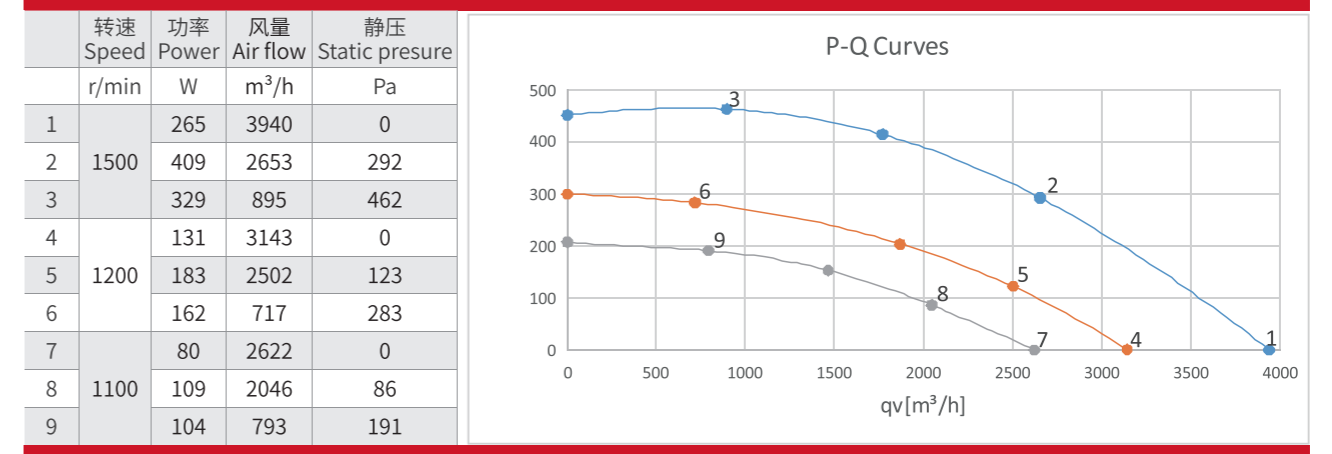

外形尺寸 Dimensions

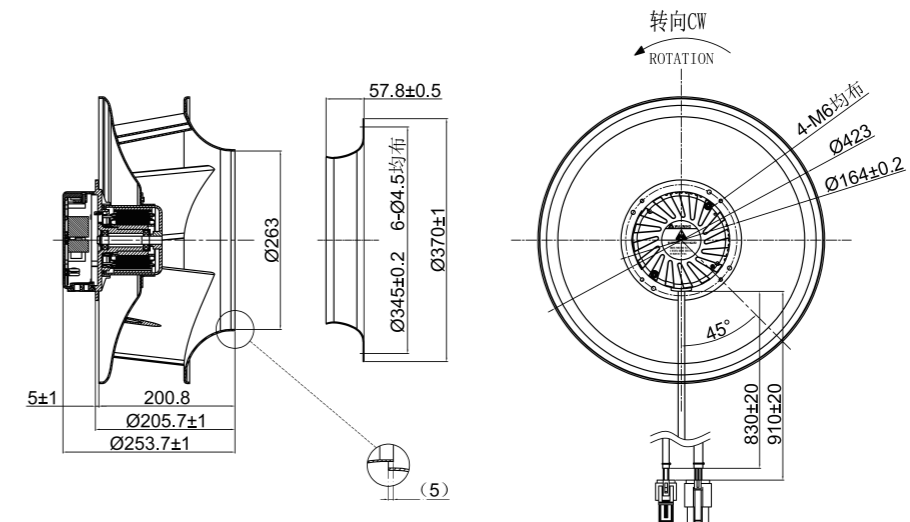



EC EXTERNAL ROTOR CENTRIFUGAL FAN BACKWARD 400

EC 外转子离心风机 后倾 400

叶轮材料: 铝合金	Impeller Material: Sheet aluminium
防护等级: IP44	Protection class: IP44
认证: CCC CE	Approvals: CCC CE
绝缘等级: F	Insulation class: F
调速方式: Vsp/RS485	Speed regulation mode: Vsp/RS485

技术参数 Specification

型号 Type	额定电压 Nominal voltage	频率 Frequency	转速 Speed	额定功率 Rated Power	电流 Current	噪音 LpA	使用温度 Perm.amb.temp.
FCB400A/ EEW0S***-R	[VAC]	[Hz]	[rpm]	[W]	[A]	[dB(A)]	[°C]
	1~200-277	50/60	1450	390	1.7	68	-25°C ~+60°C

P-Q 曲线 P-Q Curves

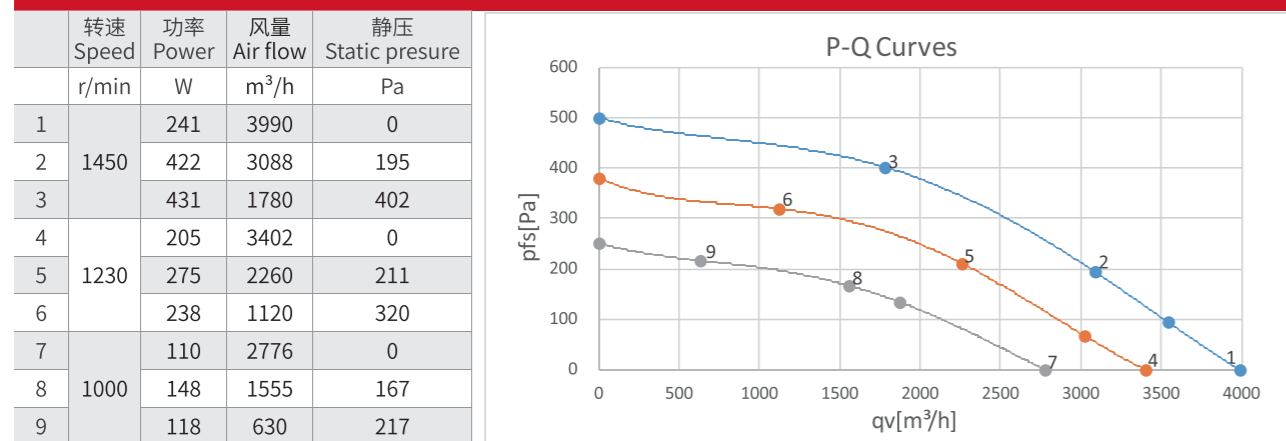

外形尺寸 Dimensions

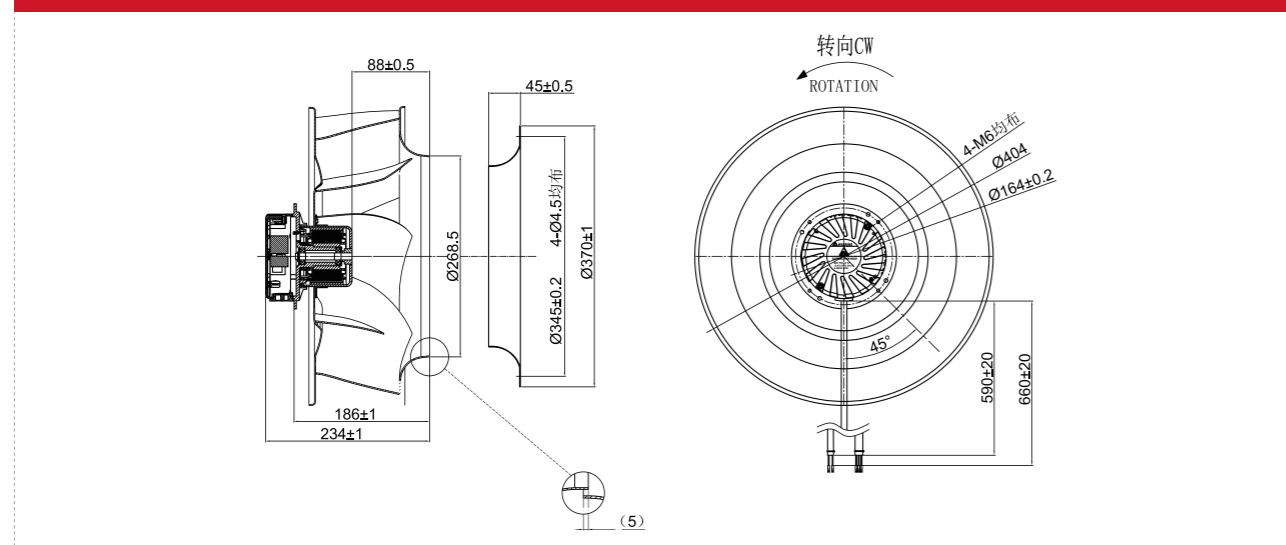

EC EXTERNAL ROTOR CENTRIFUGAL FAN BACKWARD 450

EC 外转子离心风机 后倾 450

叶轮材料: 铝合金	Impeller Material: Sheet aluminium
防护等级: IP55	Protection class: IP55
认证: CCC CE	Approvals: CCC CE
绝缘等级: F	Insulation class: F
调速方式: Vsp/RS485	Speed regulation mode: Vsp/RS485

技术参数 Specification

型号 Type	额定电压 Nominal voltage	频率 Frequency	转速 Speed	额定功率 Rated Power	电流 Current	噪音 LpA	使用温度 Perm.amb.temp.
FCB450A/ EEX0T***-R	[VAC]	[Hz]	[rpm]	[W]	[A]	[dB(A)]	[°C]
	3~380-480	50/60	1400	950	1.6	72	-20°C ~+60°C

P-Q 曲线 P-Q Curves

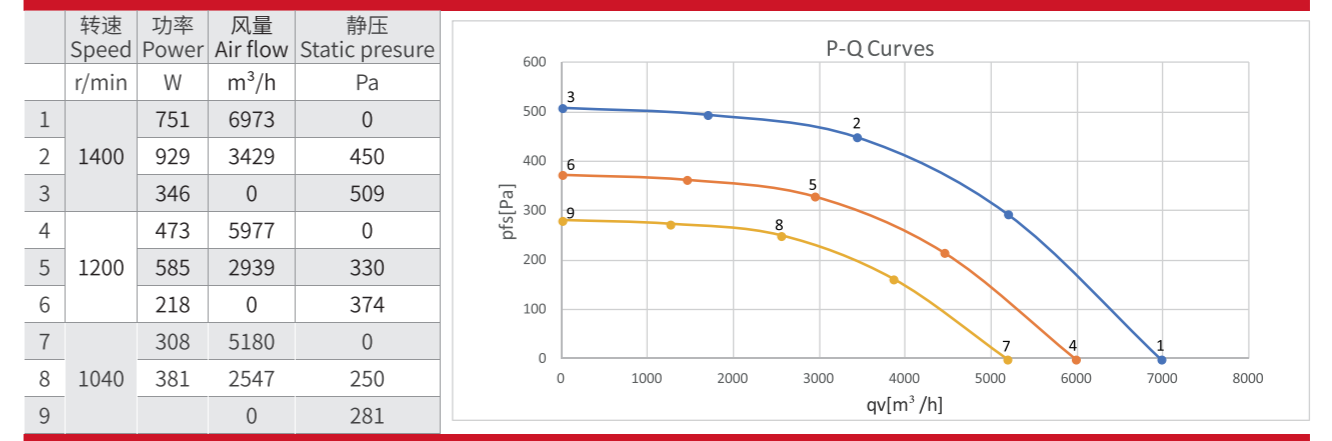

外形尺寸 Dimensions

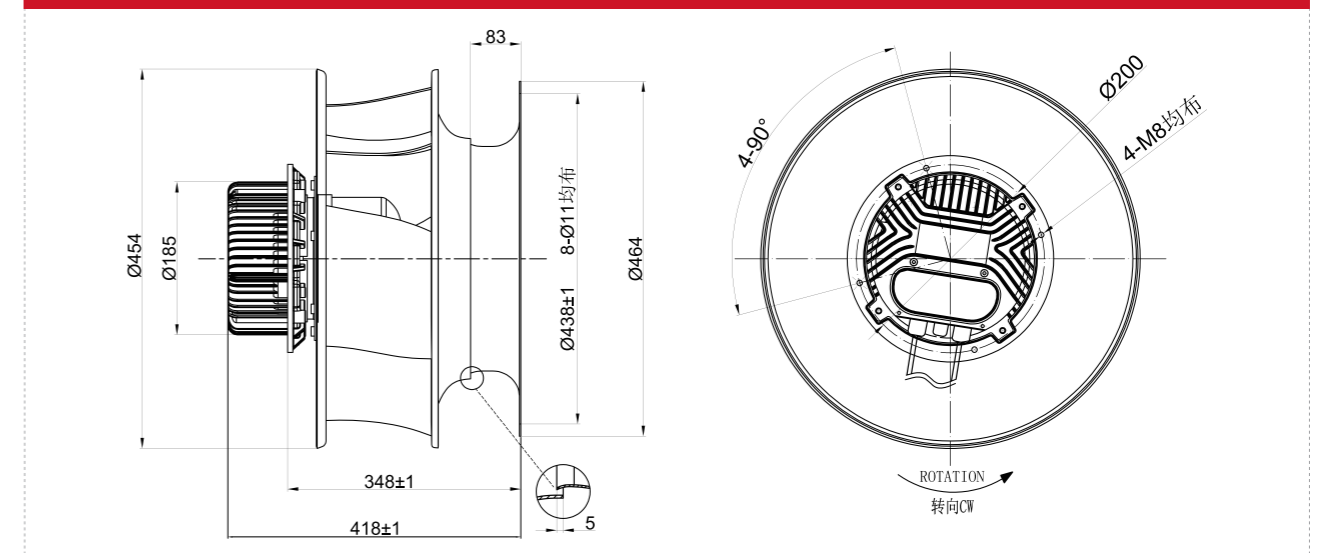



EC EXTERNAL ROTOR CENTRIFUGAL FAN BACKWARD 630

EC 外转子离心风机 后倾 630

叶轮材料: PP+40%GF	Impeller Material: PP+40%GF
防护等级: IP55	Protection class: IP55
认证: CCC CE	Approvals: CCC CE
绝缘等级: F	Insulation class: F
调速方式: Vsp/RS485	Speed regulation mode: Vsp/RS485

技术参数 Specification

型号 Type	额定电压 Nominal voltage	频率 Frequency	转速 Speed	额定功率 Rated Power	电流 Current	噪音 LpA	使用温度 Perm.amb.temp.
FCB630R/ EEY0T***-R	[VAC]	[Hz]	[rpm]	[W]	[A]	[dB(A)]	[°C]
	3~ 380-480	50/60	1420	3900	6.4	68	0°C ~+40°C

P-Q 曲线 P-Q Curves

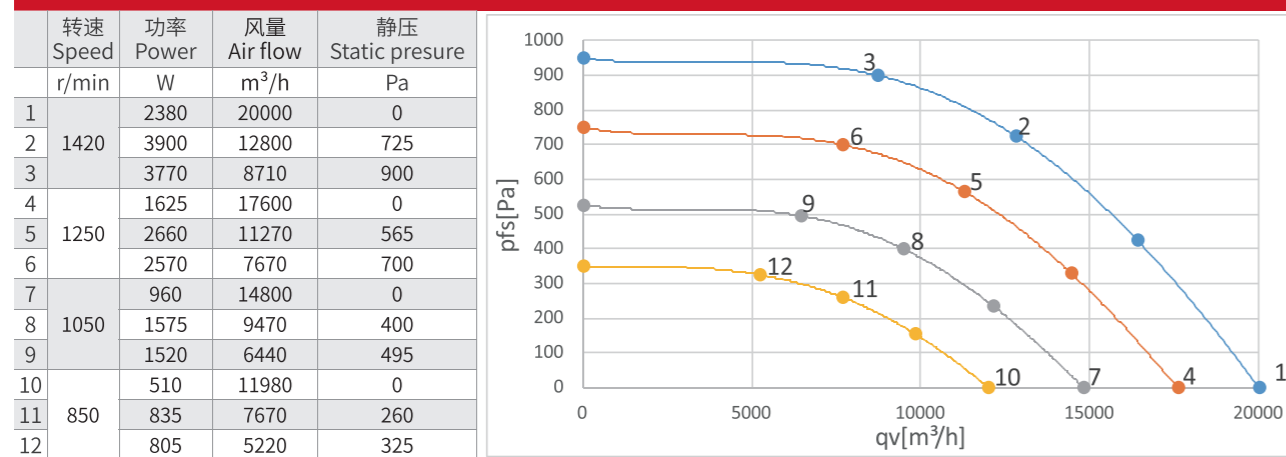

外形尺寸 Dimensions

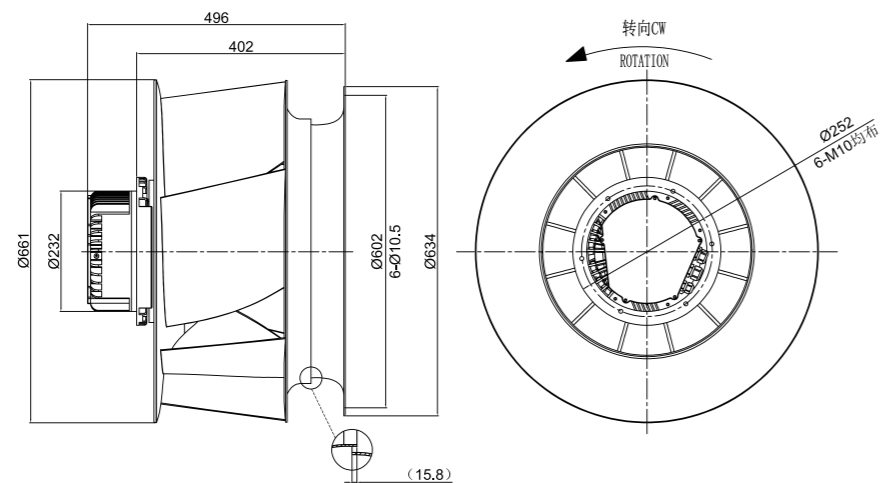

EC Axial Fan

EC 轴流风机





EC INTERNAL ROTOR AXIAL FAN 450

EC 内转子轴流风机 450

叶轮材料: 铝合金	Impeller Material: Sheet aluminium
防护等级: IP66	Protection class: IP66
认证: CCC CE	Approvals: CCC CE
绝缘等级: F	Insulation class: F
调速方式: Vsp/PWM/RS485	Speed regulation mode: Vsp/PWM/RS485

技术参数 Specification

型号 Type	额定电压 Nominal voltage	频率 Frequency	转速 Speed	额定功率 Rated Power	电流 Current	噪音 LpA	使用温度 Perm.amb.temp.
	[VAC]	[Hz]	[rpm]	[W]	[A]	[dB(A)]	[°C]
FAS450A/ IEB0S***-S	1~115\200-240	50/60	200-1400	400	1.6	72	-20°C ~+60°C

P-Q 曲线 P-Q Curves

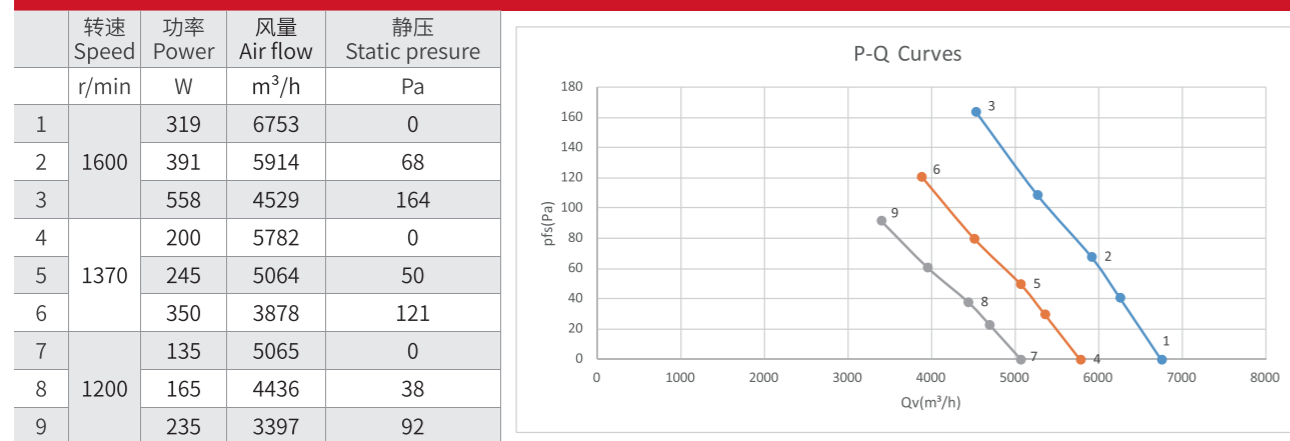

外形尺寸 Dimensions

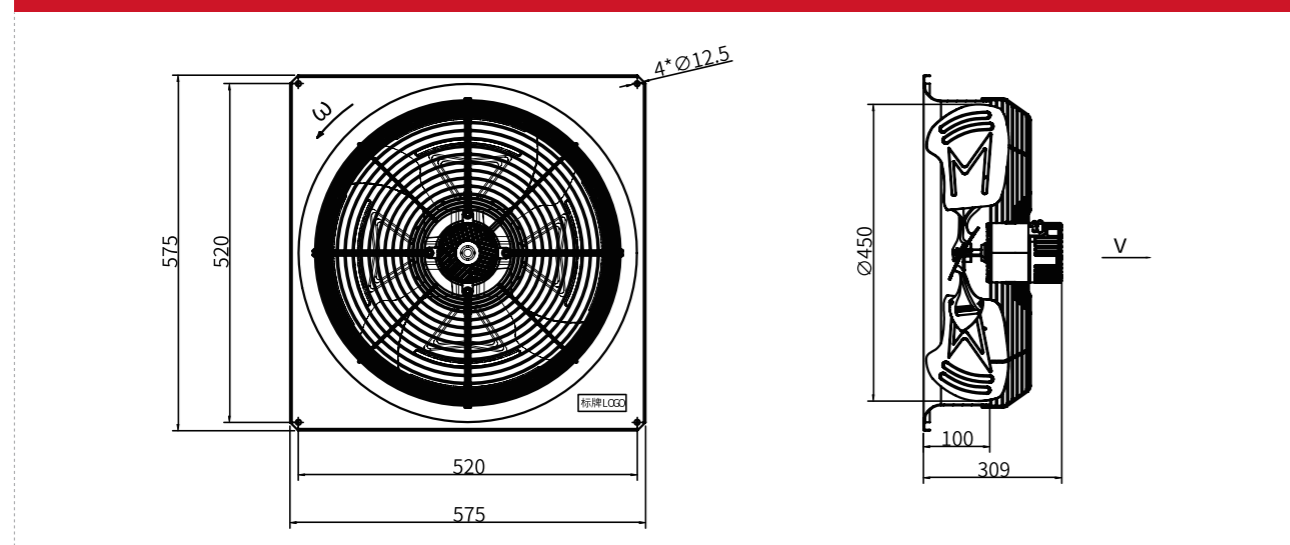

EC INTERNAL ROTOR AXIAL FAN 500

EC 内转子轴流风机 500

叶轮材料: 铝合金	Impeller Material: Sheet aluminium
防护等级: IP66	Protection class: IP66
认证: CCC CE	Approvals: CCC CE
绝缘等级: F	Insulation class: F
调速方式: Vsp/PWM/RS485	Speed regulation mode: Vsp/PWM/RS485

技术参数 Specification

型号 Type	额定电压 Nominal voltage	频率 Frequency	转速 Speed	额定功率 Rated Power	电流 Current	噪音 LpA	使用温度 Perm.amb.temp.
	[VAC]	[Hz]	[rpm]	[W]	[A]	[dB(A)]	[°C]
FAS500A/ IEB1S***-S	1~115\200-240	50/60	200-1400	561	2.5	73	-20°C ~+60°C

P-Q 曲线 P-Q Curves

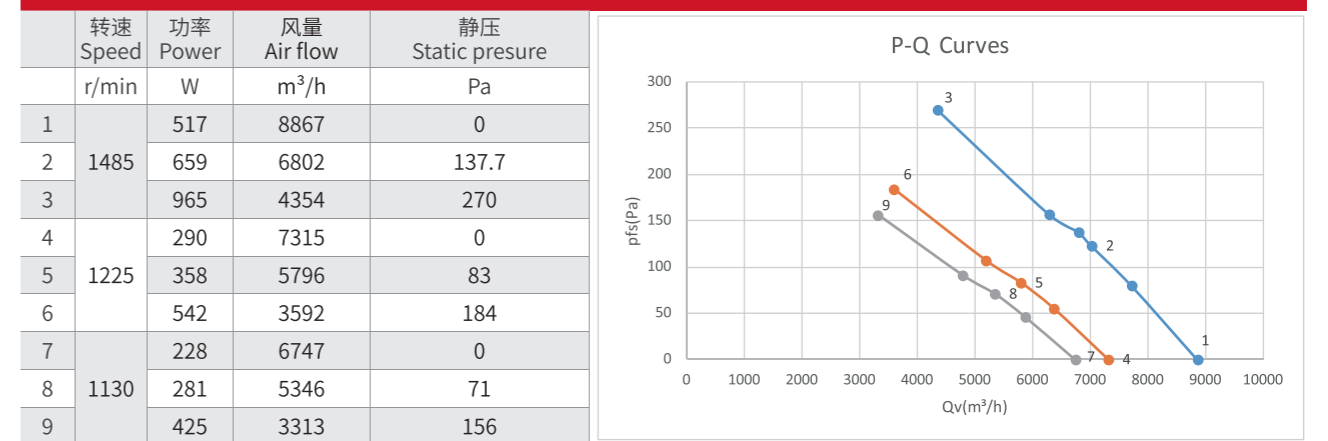

外形尺寸 Dimensions

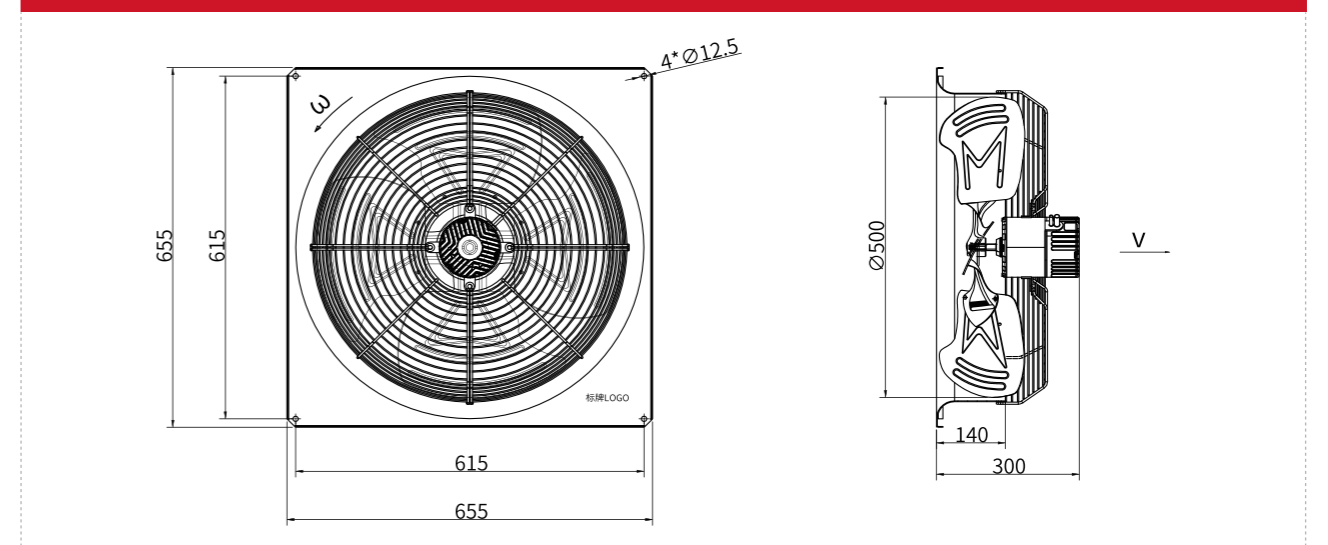



EC INTERNAL ROTOR AXIAL FAN 560

EC 内转子轴流风机 560

叶轮材料: 铝合金	Impeller Material: Sheet aluminium
防护等级: IP66	Protection class: IP66
认证: CCC CE	Approvals: CCC CE
绝缘等级: F	Insulation class: F
调速方式: Vsp/PWM/RS485	Speed regulation mode: Vsp/PWM/RS485



EC INTERNAL ROTOR AXIAL FAN 630

EC 内转子轴流风机 630

叶轮材料: 铝合金	Impeller Material: Sheet aluminium
防护等级: IP66	Protection class: IP66
认证: CCC CE	Approvals: CCC CE
绝缘等级: F	Insulation class: F
调速方式: Vsp/PWM/RS485	Speed regulation mode: Vsp/PWM/RS485

技术参数 Specification

型号 Type	额定电压 Nominal voltage	频率 Frequency	转速 Speed	额定功率 Rated Power	电流 Current	噪音 LpA	使用温度 Perm.amb.temp.
	[VAC]	[Hz]	[rpm]	[W]	[A]	[dB(A)]	[°C]
FAS560A/ IEB1S***-S	1~115\200-240	50/60	200-1200	630	2	76.8	-20°C ~+60°C

P-Q 曲线 P-Q Curves

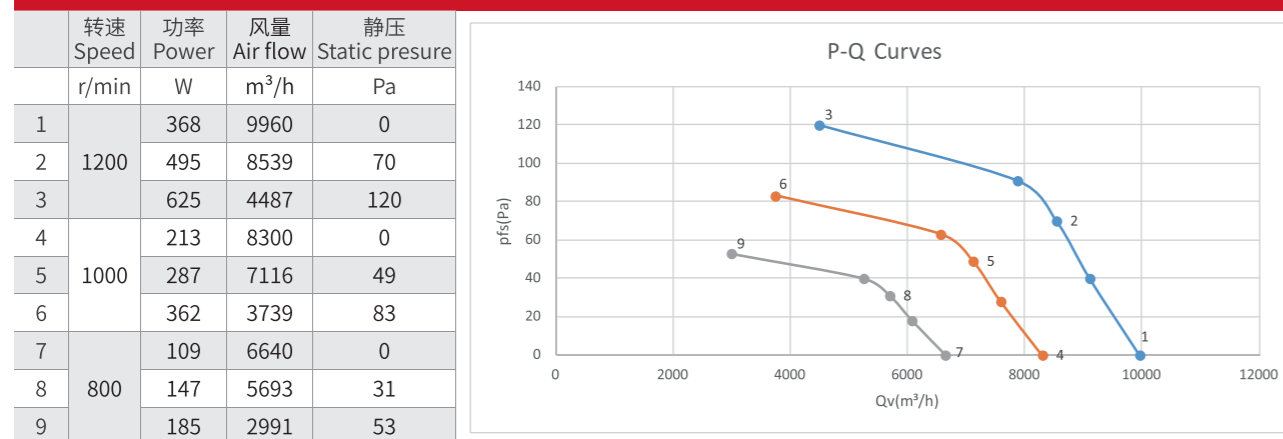

外形尺寸 Dimensions

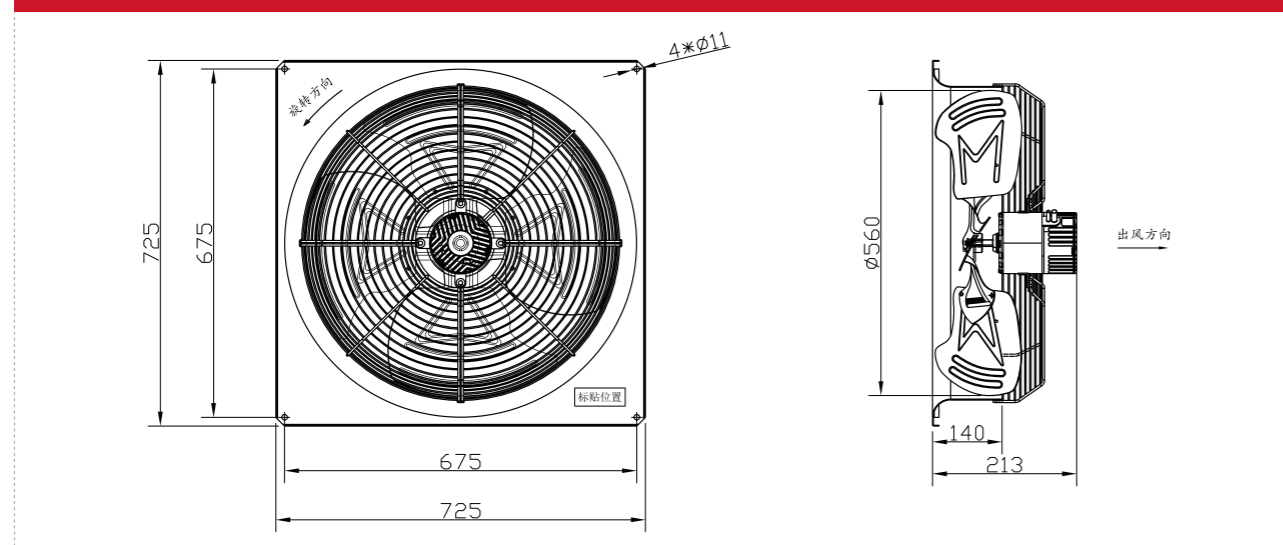

技术参数 Specification

型号 Type	额定电压 Nominal voltage	频率 Frequency	转速 Speed	额定功率 Rated Power	电流 Current	噪音 LpA	使用温度 Perm.amb.temp.
	[VAC]	[Hz]	[rpm]	[W]	[A]	[dB(A)]	[°C]
FAS630A/ IEB2S***-S	1~115\200-240	50/60	200-1060	885	2.1	75	-20°C ~+60°C

P-Q 曲线 P-Q Curves

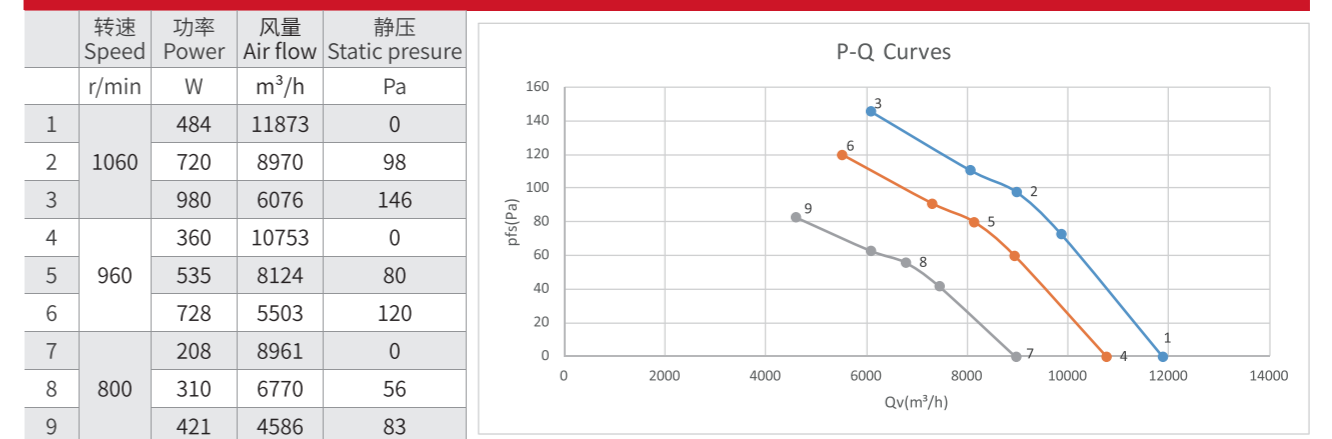

外形尺寸 Dimensions

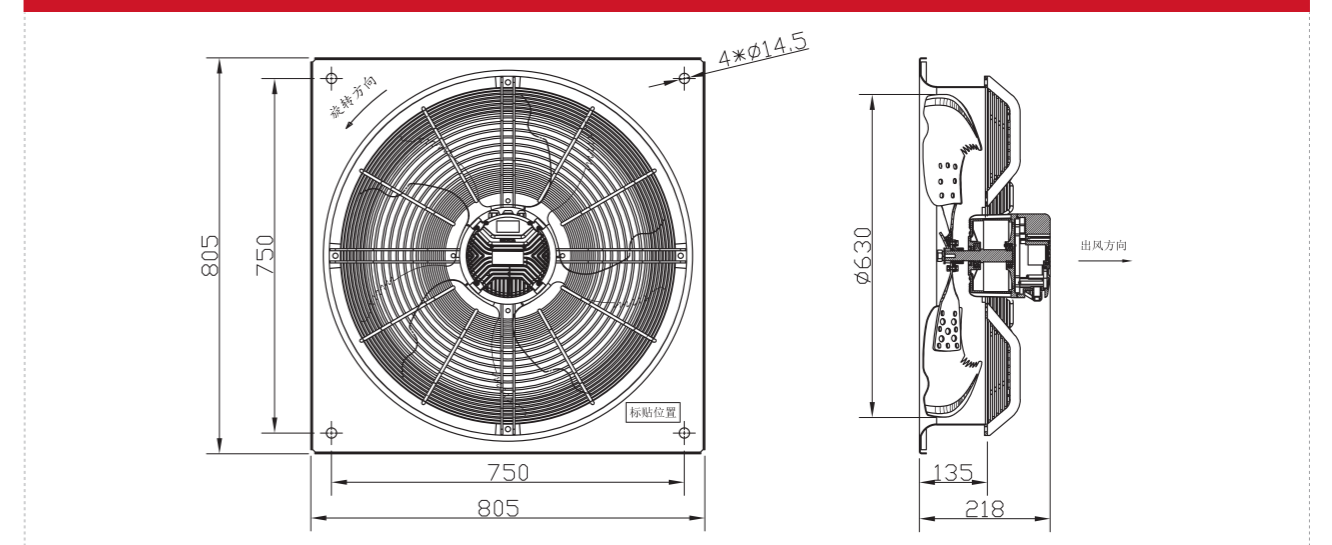



EC INTERNAL ROTOR AXIAL FAN 710

EC 内转子轴流风机 710

叶轮材料: 铝合金	Impeller Material: Sheet aluminium
防护等级: IP66	Protection class: IP66
认证: CCC CE	Approvals: CCC CE
绝缘等级: F	Insulation class: F
调速方式: Vsp/PWM/RS485	Speed regulation mode: Vsp/PWM/RS485



EC INTERNAL ROTOR AXIAL FAN 760

EC 内转子轴流风机 760

叶轮材料: 铝合金	Impeller Material: Sheet aluminium
防护等级: IP66	Protection class: IP66
认证: CCC CE	Approvals: CCC CE
绝缘等级: F	Insulation class: F
调速方式: Vsp/RS485	Speed regulation mode: Vsp/RS485

技术参数 Specification

型号 Type	额定电压 Nominal voltage	频率 Frequency	转速 Speed	额定功率 Rated Power	电流 Current	噪音 LpA	使用温度 Perm.amb.temp.
	[VAC]	[Hz]	[rpm]	[W]	[A]	[dB(A)]	[°C]
FAST10A/ IEB2S***-S	1~115\200-240	50/60	200-870	790	2.3	70	-20°C ~+60°C

P-Q 曲线 P-Q Curves

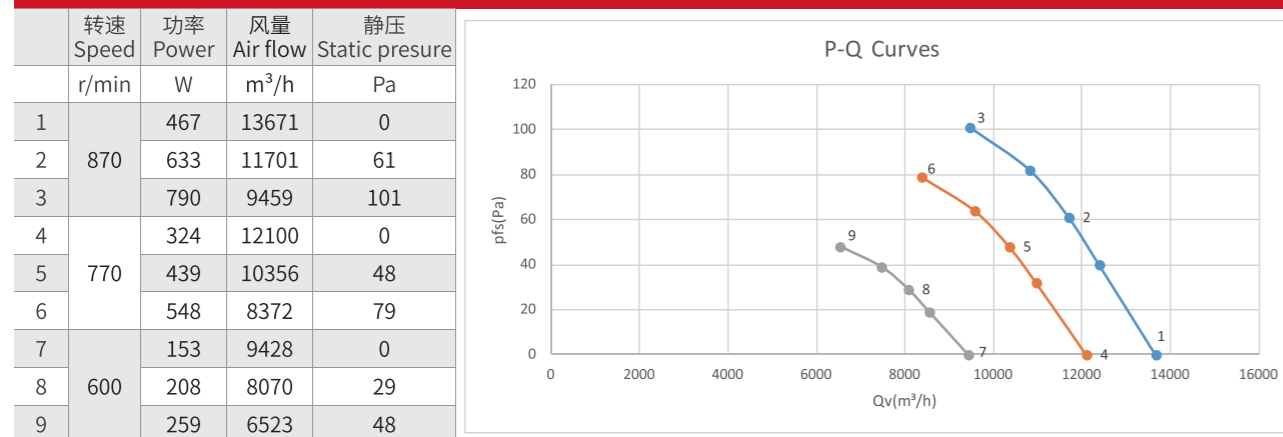

外形尺寸 Dimensions

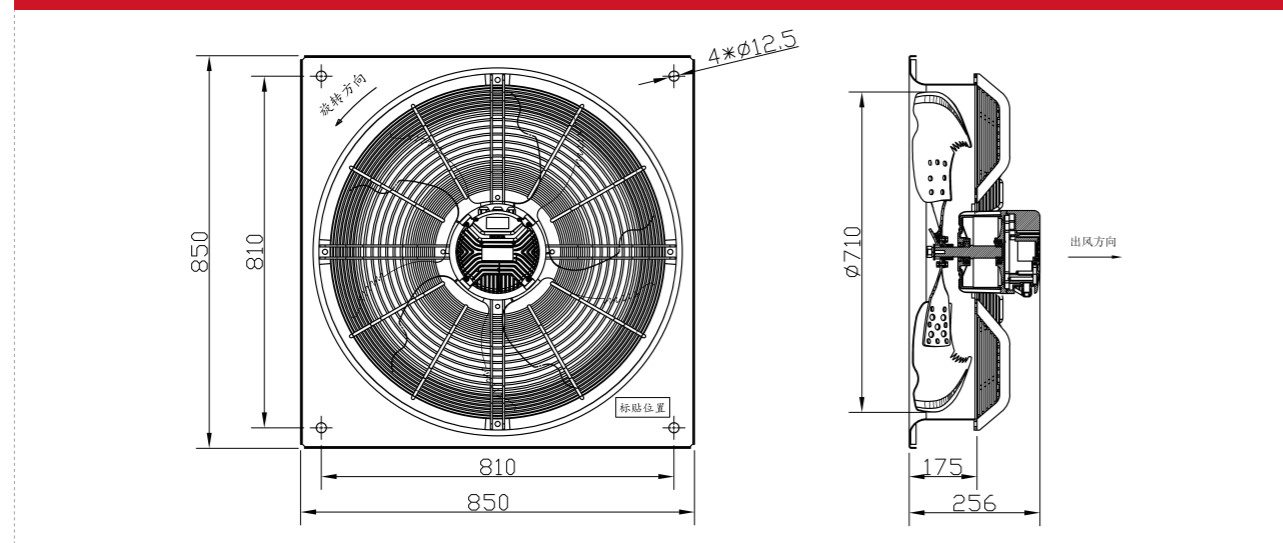

技术参数 Specification

型号 Type	额定电压 Nominal voltage	频率 Frequency	转速 Speed	额定功率 Rated Power	电流 Current	噪音 LpA	使用温度 Perm.amb.temp.
	[VAC]	[Hz]	[rpm]	[W]	[A]	[dB(A)]	[°C]
FAS760A/ IED0T***-S	3~380-480	50/60	200-940	1030	1.8	72	-20°C ~+60°C

P-Q 曲线 P-Q Curves

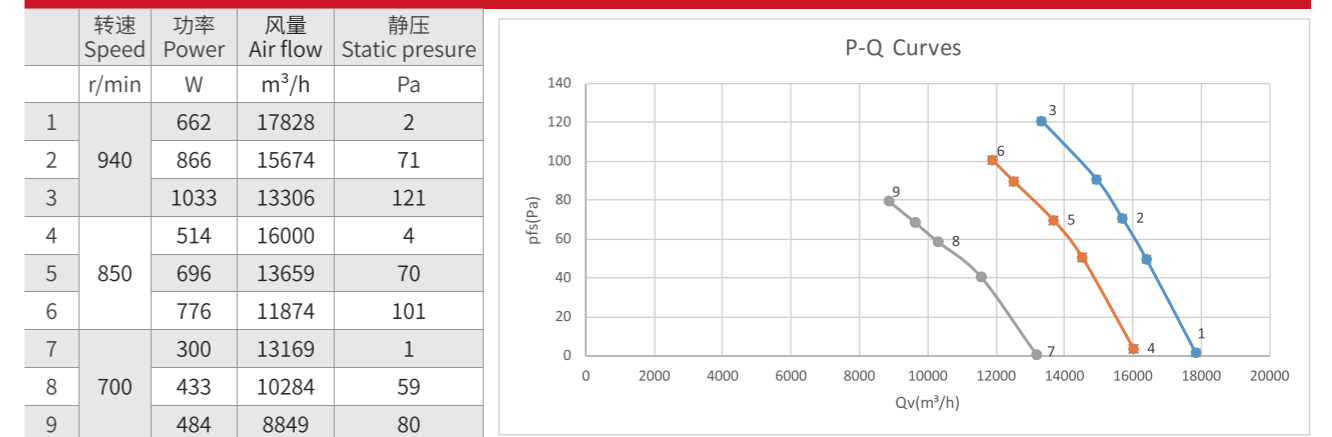

外形尺寸 Dimensions

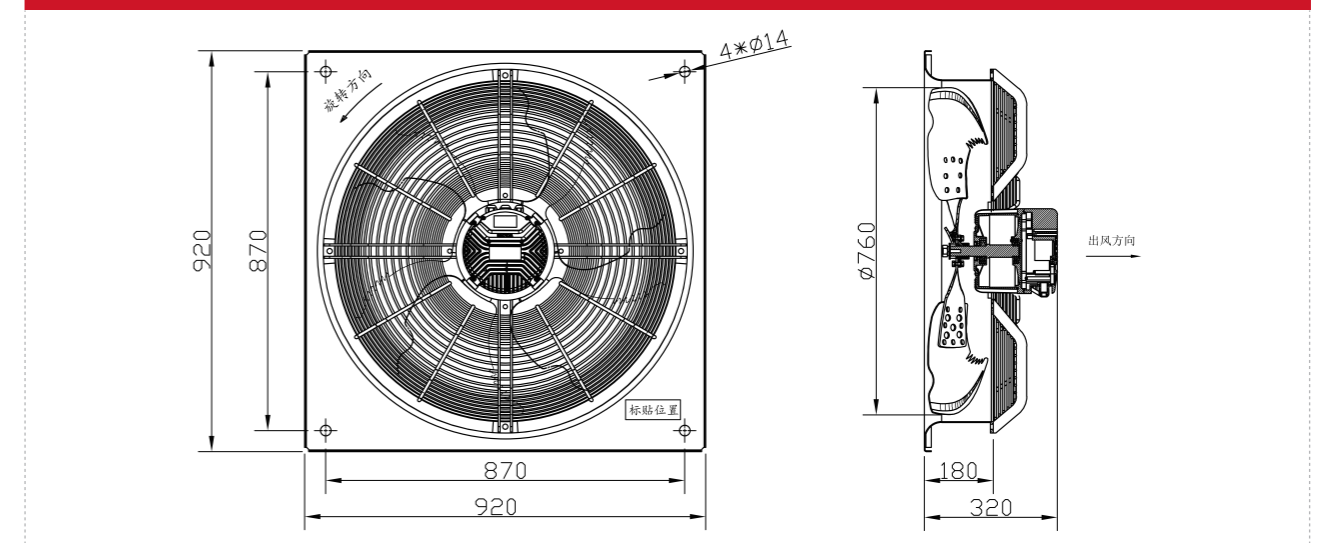



EC INTERNAL ROTOR AXIAL FAN 800

EC 内转子轴流风机 800

叶轮材料: 铝合金	Impeller Material: Sheet aluminium
防护等级: IP66	Protection class: IP66
认证: CCC CE	Approvals: CCC CE
绝缘等级: F	Insulation class: F
调速方式: Vsp/RS485	Speed regulation mode: Vsp/RS485



EC INTERNAL ROTOR AXIAL FAN 800

EC 内转子轴流风机 800

叶轮材料: 铝合金	Impeller Material: Sheet aluminium
防护等级: IP66	Protection class: IP66
认证: CCC CE	Approvals: CCC CE
绝缘等级: F	Insulation class: F
调速方式: Vsp/RS485	Speed regulation mode: Vsp/RS485

技术参数 Specification

型号 Type	额定电压 Nominal voltage	频率 Frequency	转速 Speed	额定功率 Rated Power	电流 Current	噪音 LpA	使用温度 Perm.amb.temp.
	[VAC]	[Hz]	[rpm]	[W]	[A]	[dB(A)]	[°C]
FAS800A/ IEC2T***-S	3~380-480	50/60	200-900	1778	2	75	-20°C ~+55°C

P-Q 曲线 P-Q Curves

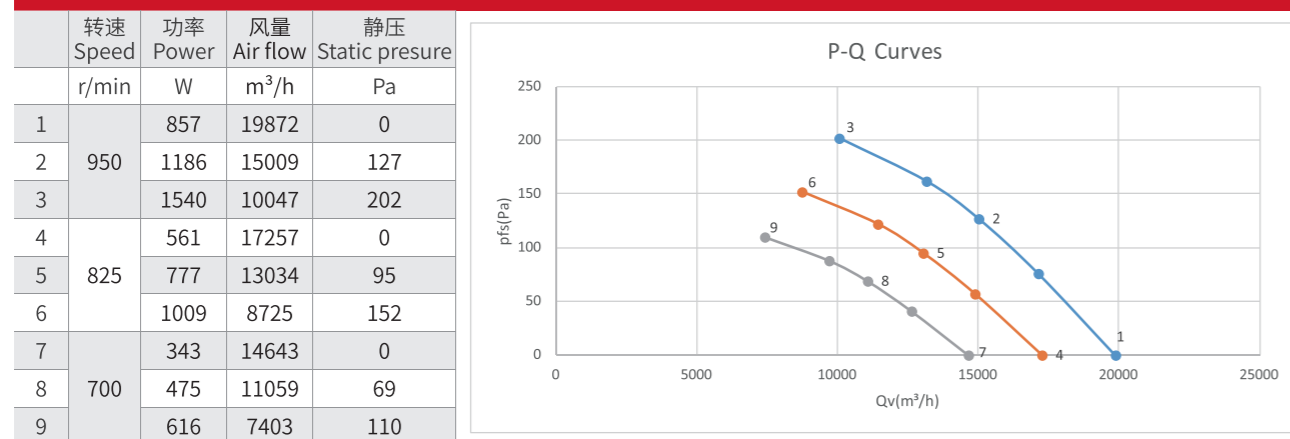

外形尺寸 Dimensions

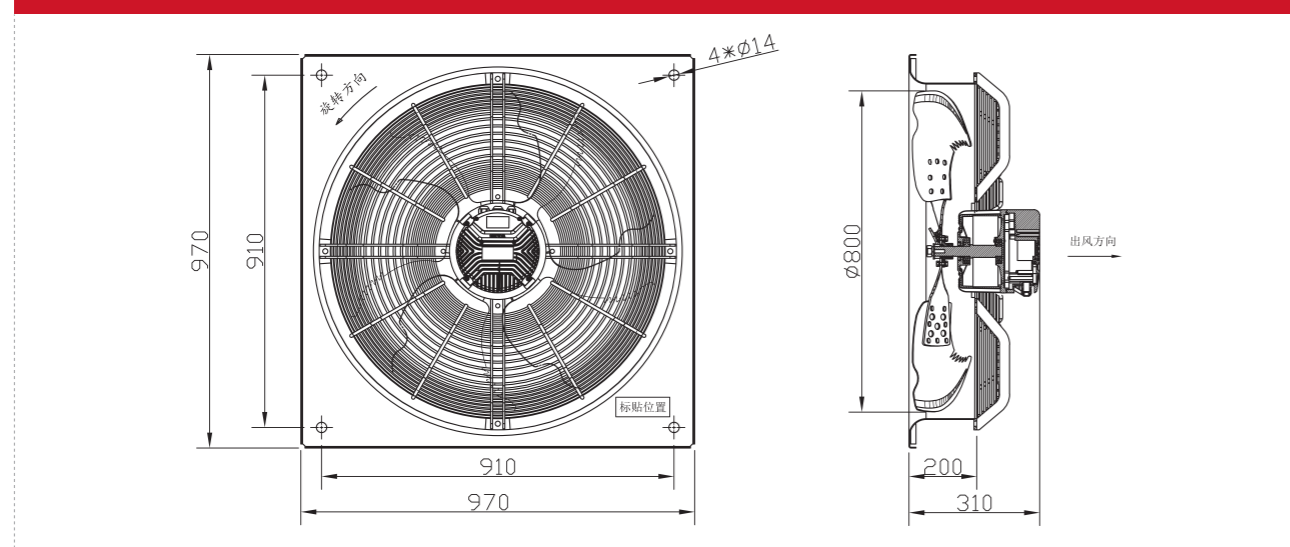

技术参数 Specification

型号 Type	额定电压 Nominal voltage	频率 Frequency	转速 Speed	额定功率 Rated Power	电流 Current	噪音 LpA	使用温度 Perm.amb.temp.
	[VAC]	[Hz]	[rpm]	[W]	[A]	[dB(A)]	[°C]
FAS800A/ IEE0T***-S	3~380-480	50/60	200-960	2254	3.5	79	-20°C ~+55°C

P-Q 曲线 P-Q Curves

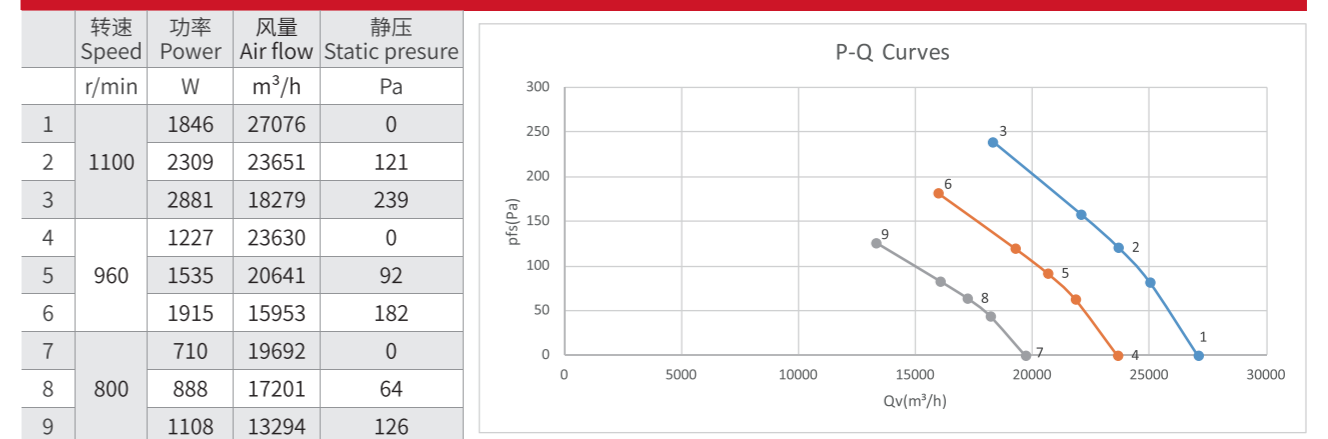

外形尺寸 Dimensions

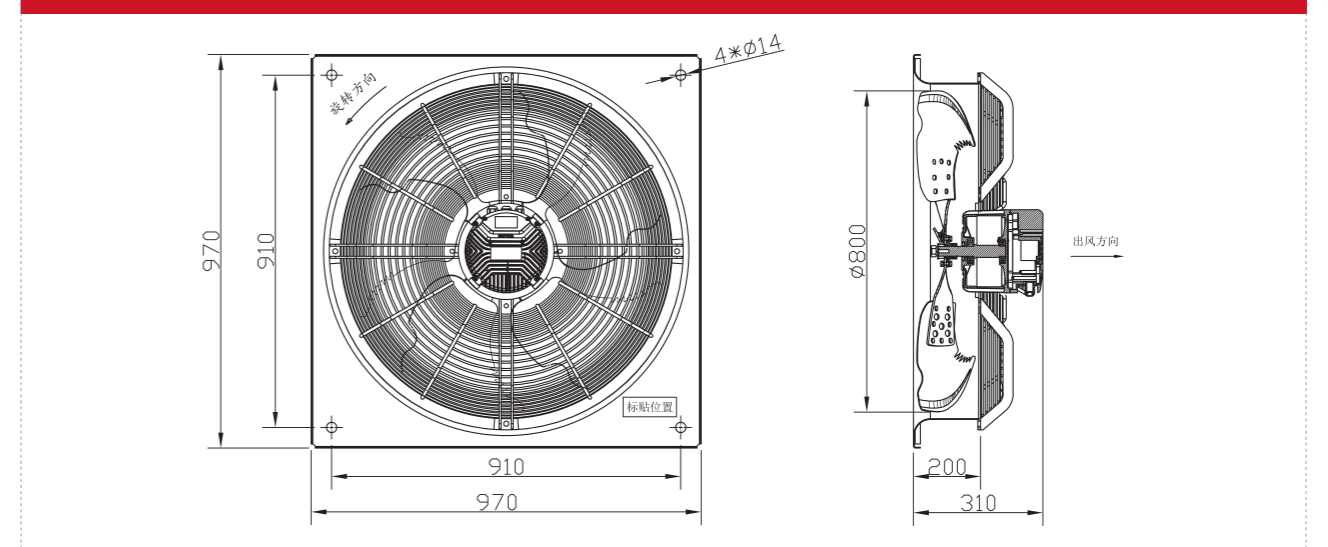



EC INTERNAL ROTOR AXIAL FAN 850

EC 内转子轴流风机 850

叶轮材料: 铝合金	Impeller Material: Sheet aluminium
防护等级: IP66	Protection class: IP66
认证: CCC CE	Approvals: CCC CE
绝缘等级: F	Insulation class: F
调速方式: Vsp/RS485	Speed regulation mode: Vsp/RS485



EC INTERNAL ROTOR AXIAL FAN 900

EC 内转子轴流风机 900

叶轮材料: 铝合金	Impeller Material: Sheet aluminium
防护等级: IP66	Protection class: IP66
认证: CCC CE	Approvals: CCC CE
绝缘等级: F	Insulation class: F
调速方式: Vsp/RS485	Speed regulation mode: Vsp/RS485

技术参数 Specification

型号 Type	额定电压 Nominal voltage	频率 Frequency	转速 Speed	额定功率 Rated Power	电流 Current	噪音 LpA	使用温度 Perm.amb.temp.
FAS850A/ IEE1T***-S	[VAC] 3~380-480	[Hz] 50/60	[rpm] 200-960	[W] 2619	[A] 7.2	[dB(A)] 81	[°C] -20°C ~+55°C

P-Q 曲线 P-Q Curves

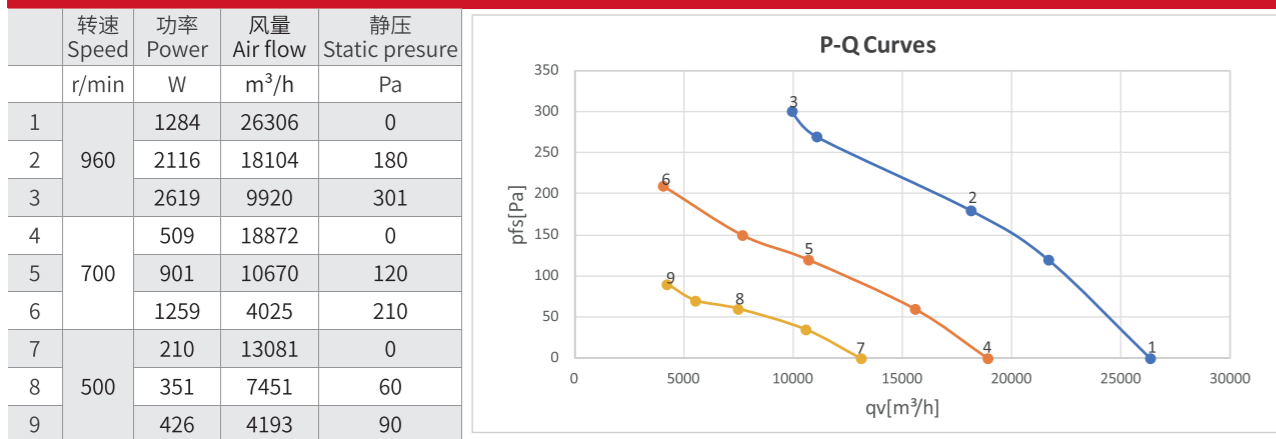

外形尺寸 Dimensions

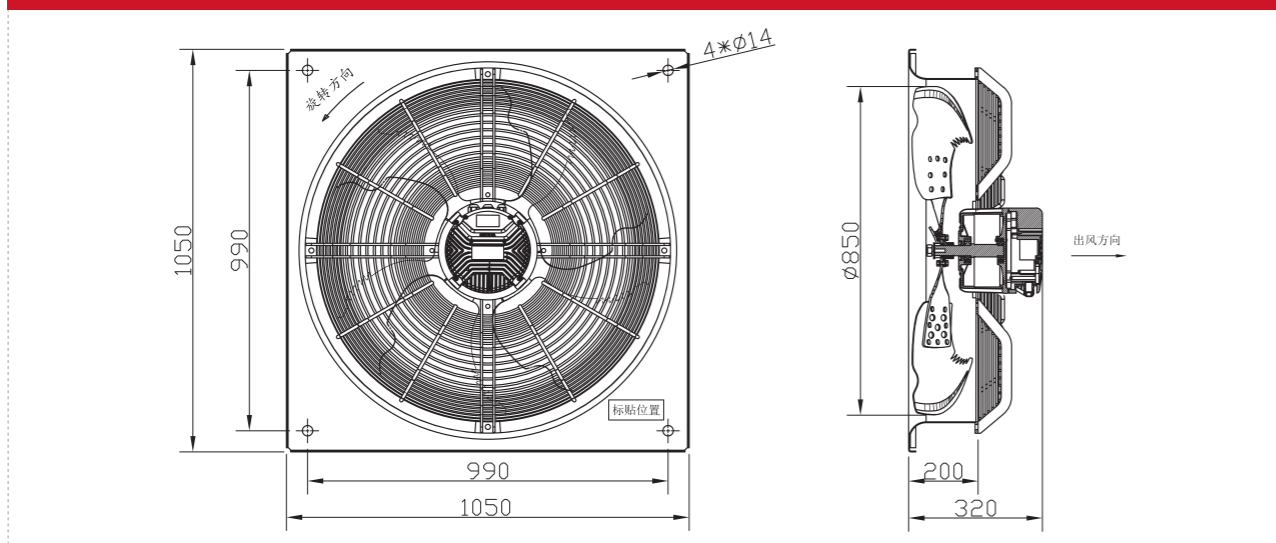

技术参数 Specification

型号 Type	额定电压 Nominal voltage	频率 Frequency	转速 Speed	额定功率 Rated Power	电流 Current	噪音 LpA	使用温度 Perm.amb.temp.
FAS900A/ IEC2T***-S	[VAC] 3~380-480	[Hz] 50/60	[rpm] 200-800	[W] 1734	[A] 3.6	[dB(A)] 78	[°C] -20°C ~+55°C

P-Q 曲线 P-Q Curves

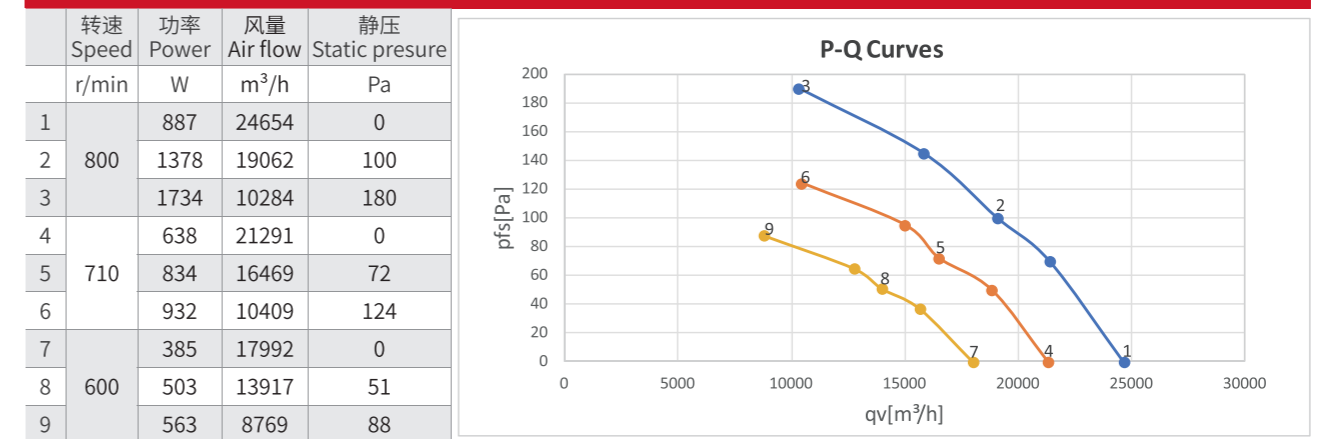

外形尺寸 Dimensions

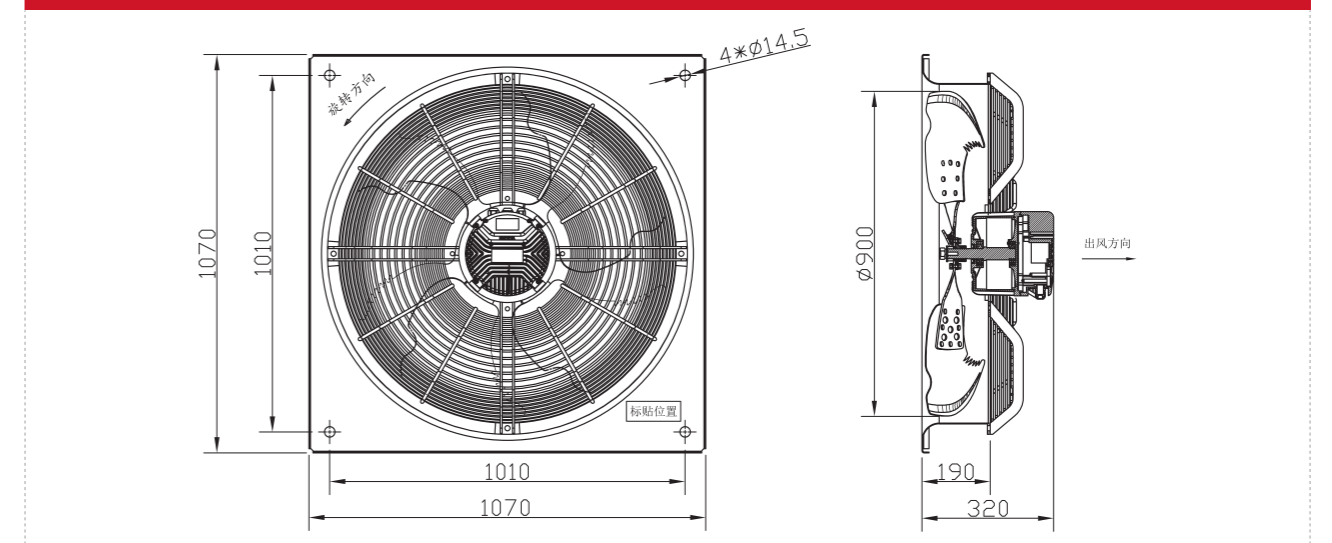



EC INTERNAL ROTOR AXIAL FAN 900

EC 内转子轴流风机 900

叶轮材料: 铝合金	Impeller Material: Sheet aluminium
防护等级: IP66	Protection class: IP66
认证: CCC CE	Approvals: CCC CE
绝缘等级: F	Insulation class: F
调速方式: Vsp/RS485	Speed regulation mode: Vsp/RS485

技术参数 Specification

型号 Type	额定电压 Nominal voltage	频率 Frequency	转速 Speed	额定功率 Rated Power	电流 Current	噪音 LpA	使用温度 Perm.amb.temp.
FAS900A/ IEE2T***-S	[VAC]	[Hz]	[rpm]	[W]	[A]	[dB(A)]	[°C]
	3~380-480	50/60	200-960	3040	5.5	82	-20°C ~+55°C

P-Q 曲线 P-Q Curves

转速 Speed	功率 Power	风量 Air flow	静压 Static pressure
r/min	W	m³/h	Pa
1	1548	29954	0
2	2347	23353	150
3	3040	11237	270
4	1029	24248	0
5	1508	18876	113
6	1744	13145	197
7	640	20699	0
8	938	16114	82
9	1085	11222	144

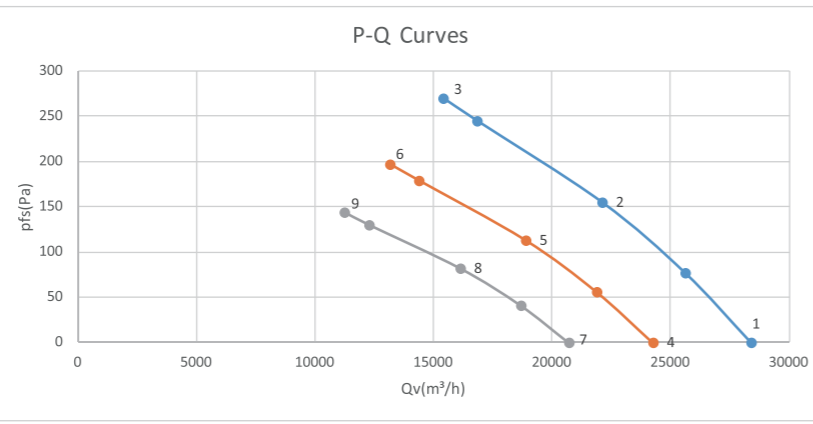

外形尺寸 Dimensions

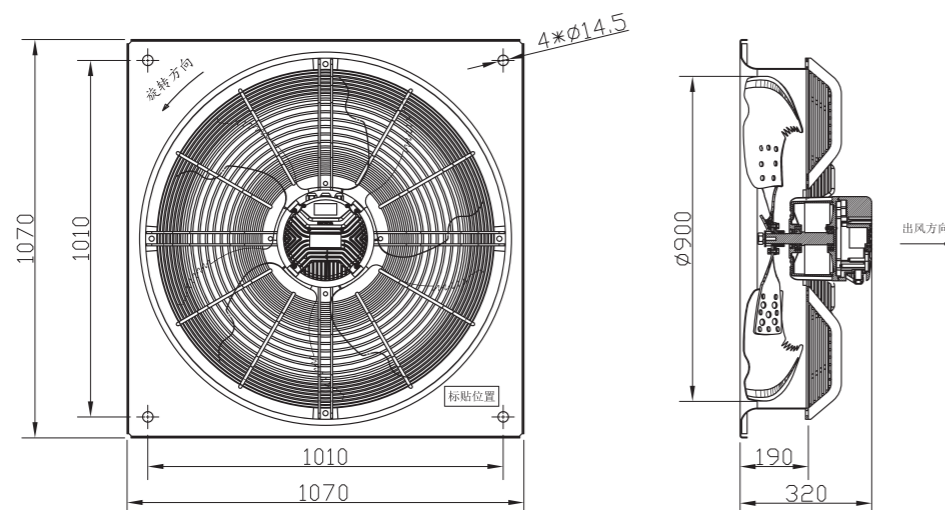

CENTRIFUGAL FAN TERMINAL FUNCTION DESCRIPTION AND CONNECTION DIAGRAM

离心风机端子功能说明及接线图

EC059&074 单相 EC059&074 single phase			0-10V 端子功能 0-10V Function of Terminal		
信号名 SIGNAL	颜色 COLOR	规格 SPEC	信号名 SIGNAL	颜色 COLOR	规格 SPEC
L	红 RED	AC230V 50/60Hz	FG	白 WHITE	12 Pulse/R
N	蓝 BLUE	AC230V 50/60Hz	Vsp	黄 YELLOW	0-10V DC/PWM
PE	绿 / 黄 GREEN/ YELLOW	接地 GND	+10V	红 RED	DC10V 输出
			GND	蓝 BLUE	GND

EC084 单相 EC084 single phase			0-10V 端子功能 0-10V Function of Terminal		
信号名 SIGNAL	颜色 COLOR	规格 SPEC	信号名 SIGNAL	颜色 COLOR	规格 SPEC
L	红 RED	AC230V50/60Hz	FG	白 WHITE	1 Pulse/R
N	黑 BLACK	AC230V50/60Hz	Vsp	红 RED	0-10VDC/PWM
PE	绿 / 黄 GREEN/ YELLOW	接地 EARTH	+10V	黄 YELLOW	DC10V 输出
			GND	蓝 BLUE	GND

EC084 单相 EC084 single phase			RS485 端子功能 RS485 Function of Terminal		
信号名 SIGNAL	颜色 COLOR	规格 SPEC	信号名 SIGNAL	颜色 COLOR	规格 SPEC
L	红 RED	AC230V50/60Hz	RS485-	白 WHITE	RS485-
N	黑 BLACK	AC230V50/60Hz	RS485+	黄 YELLOW	RS485+
PE	绿 / 黄 GREEN/ YELLOW	接地 EARTH	LED1	红 RED	LED1
			LED2	蓝 BLUE	LED2

EC059&074&084 单相 0-10V 调速方式接线图 Single-phase 0-10V speed regulation connection diagram

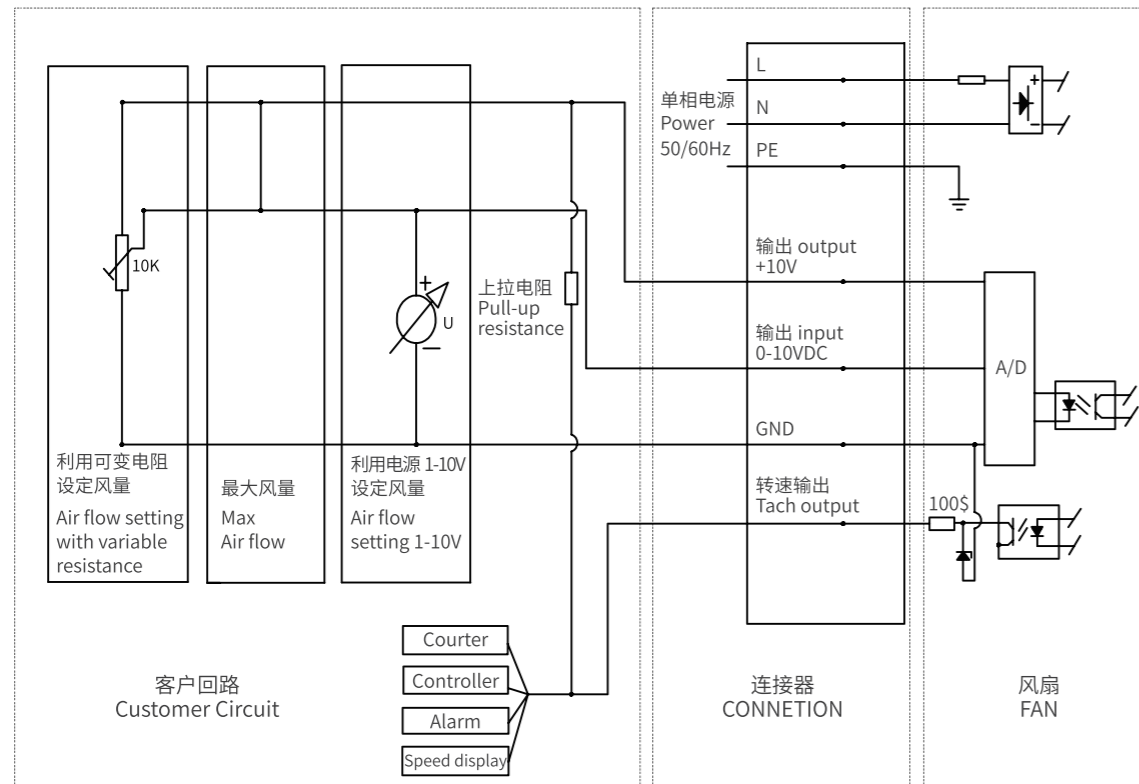

EC084 单相 RS485 调速方式接线图 Single-phase RS485 speed control connection diagram

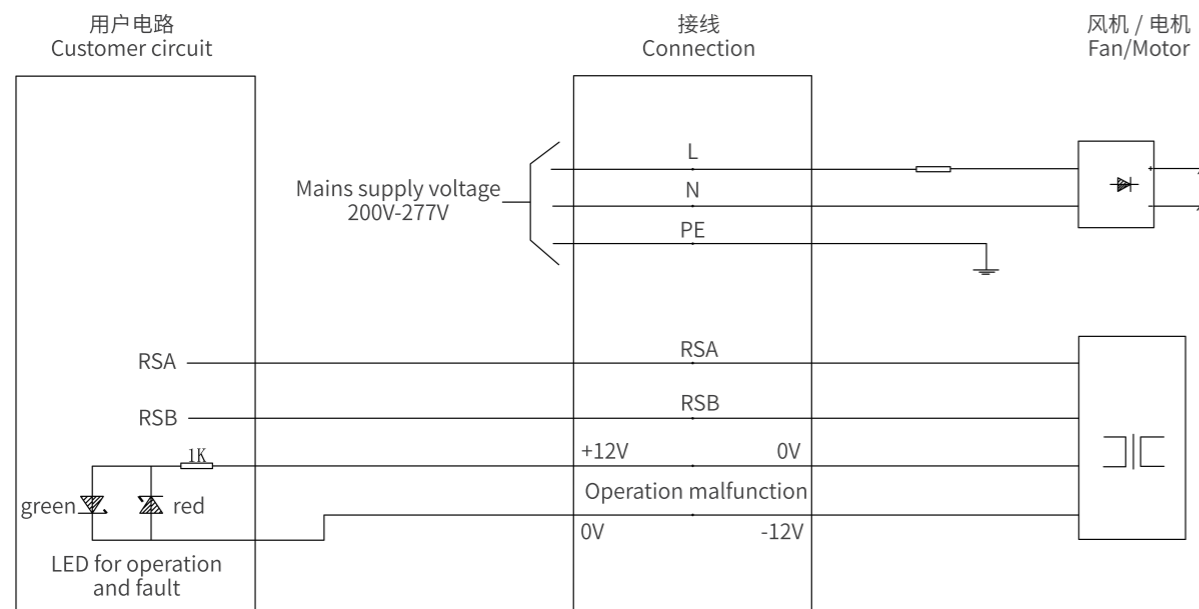

EC084 三相 EC084 Three phase

端子功能 Function of Terminal

名称 Name	功能 Function
L1	电源输入相 1 Input phase 1
L2	电源输入相 2 Input phase 2
L3	电源输入相 3 Input phase 3
PE	保护接地 Protective earth
COM	故障输出接口, 常开触点 Failure output interface, always open contacts
NO	
GND	参考地 Reference place
A1	0-10V 调速输入接口 0-10V speed control input interface
10V	内部 10V 直流电压 Internal 10V DC voltage
D1	电机启动使能接口, 高电平启动 Motor start enable interface, high level start
24V	内部 24V 直流电压 Internal 24V DC voltage
485A	485 通讯接口 485 communication interface
485B	
SW	485 通讯端电阻接口 485 Communication Terminal Resistance interface

EC084 三相接线图 EC084 three-phase connection diagram

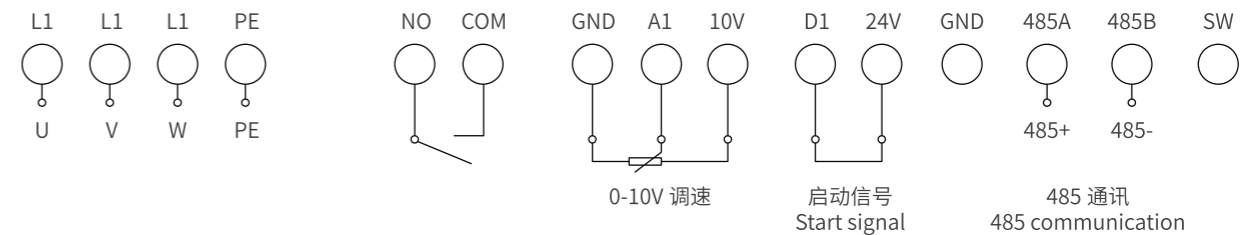

EC156 三相 EC156Three phase		端子功能 Function of Terminal
名称 Name	功能 Function	
L1	三相电源输入 1 Three-phase power input 1	
L2	三相电源输入 2 Three-phase power input 2	
L3	三相电源输入 3 Three-phase power input 3	
PE	保护接地 Protective earth	
GND	信号地 signal ground	
A1	模拟输入 1 (0-10V 调速) Analog input 1 (0-10V speed regulation)	
10V	10V 电源输出 10V power output	
D1	数字输入 1 digital input 1 电机启动使能信号 (使用 0-10V 调速时有效) Motor start enable signal (valid when using 0-10V speed regulation)	
	数字输入 2 digital input 2 电机转向控制信号 (使用 0-10V 调速时有效) Motor steering control signal (valid when using 0-10V speed regulation)	
24V	24V 电源输出	
GND	信号地 signal ground	
485A	RS485B 通讯输入 RS485B communication input	
485B	RS485B 通讯输入 RS485B communication input	
SW	通过短接 485B 和 SW 接线端子实现 120 欧姆电阻端接 120 Ohm Resistor Termination by Shorting 485B and SW Terminal Blocks	
NO	继电器常开触点, 故障后闭合 Relay normally open contact, closed after fault	
NC	继电器常闭触点, 故障后断开 Relay normally closed contact, disconnected after failure	
COM	公共端 public terminal	
LED	信号灯 signal lights	绿灯闪烁: 电机正常 Blinking green light: the motor is normal
		红灯闪烁: 电机故障 Flashing red light: motor failure

EC156 三相接线图 EC156 three-phase connection diagram



AXIAL FAN TERMINAL FUNCTION DESCRIPTION AND CONNECTION DIAGRAM

轴流风机端子功能说明及接线图

EC112 端子功能说明 EC112 terminal function description

名称 Name	功能 Function	
L1	电源输入相 1 Input phase 1	112
L2	电源输入相 2 Input phase 2	
L3	电源输入相 3 Input phase 3	
PE	保护接地 Protective earth	
COM	输出继电器共用触点 Output Relay common contact	
NO	输出继电器无接触 Output relay N.O. contact	
NC	输出继电器直流接触 Output relay N.C. contact	
GND1	信号接地 Signal ground	
+10V	内部 10V 直流电压 Internal 10V DC voltage	
GND1	信号接地 Signal ground	
A1	0-10V 速度控制输入接口 0-10V speed control input interface	
A2	模拟输入 2 Analog Input 2	485 通讯接口 / 485 communication interface
AOut	模拟输入 Analog Output	
D1	电机启动使能接口, 高电平启动 Motor start enable interface, high level start	
D2	转向变换接口, 高 / 低电平切换 Steering conversion interface, high/low level switching	
GND1	信号接地 Signal ground	
485A	RS 485 data +	
485B	RS 485 data -	
GND1	RS 485 ground	

EC112 端子功能说明 EC112 terminal function description

名称 Name	功能 Function	
L1	电源输入相 1 Input phase 1	132
L2	电源输入相 2 Input phase 2	
L3	电源输入相 3 Input phase 3	
PE	保护接地 Protective earth	
COM	故障输出接口, 正常开启接触 Fault output interface, normally open contact	
NO	Output relay N.C. contact	
+10V	内部 10V 直流电压 Internal 10V DC voltage	
A1	0-10V 速度控制输入接口 0-10V speed control input interface	
A2	模拟输入 2 Analog Input 2	
AOut	模拟输入 Analog Output	
D1	电机启动使能接口, 高电平启动 Motor start enable interface, high level start	
D2	转向变换接口, 高 / 低电平切换 Steering conversion interface, high/low level switching	
485A	485 通讯接口 485 communication interface	
485B		
485G		
U、V、W	连接到电机 Connect to the motor	
GND	参考地 Reference place	

EC48 单相 & 三相接线图 EC48 single-phase & three-phase connection diagram

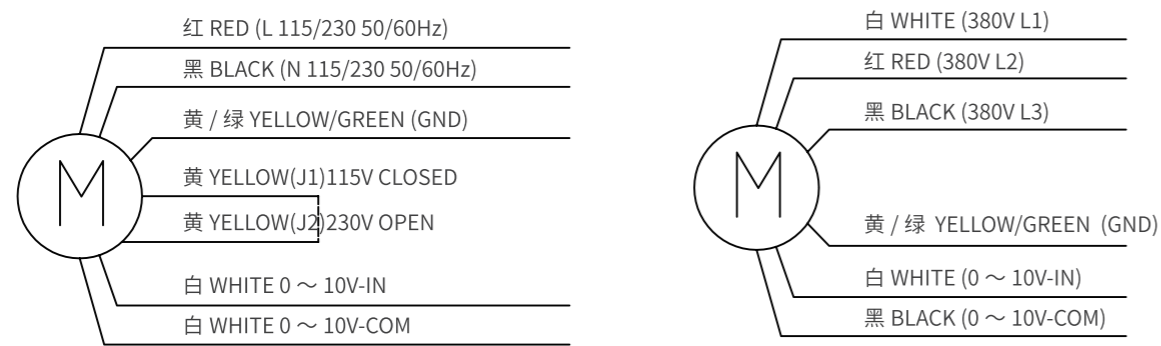

EC112 接线图 EC112 connection diagram

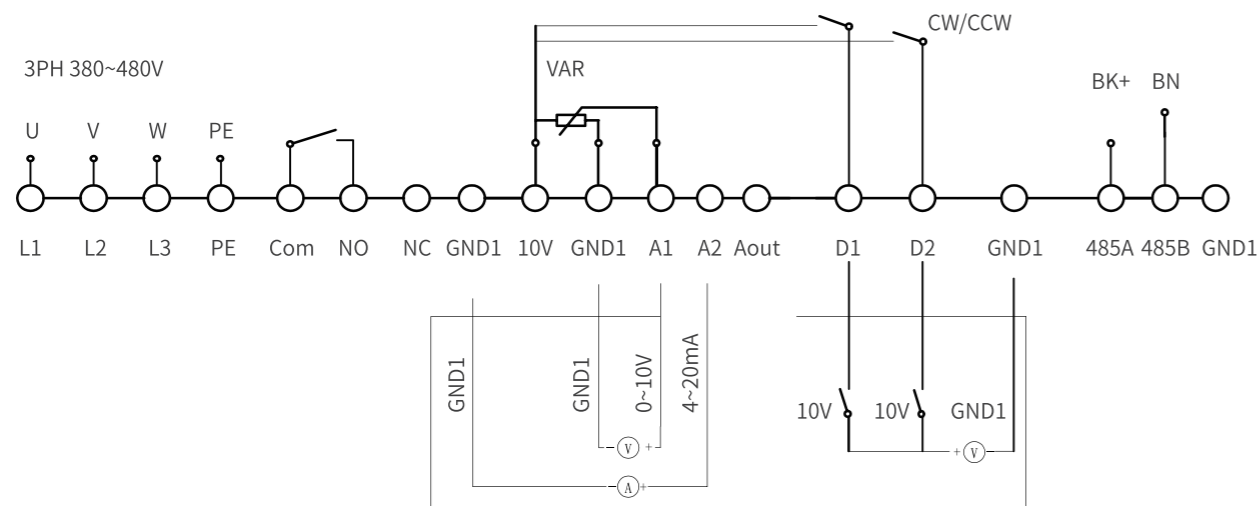

EC132 接线图 EC132 connection diagram

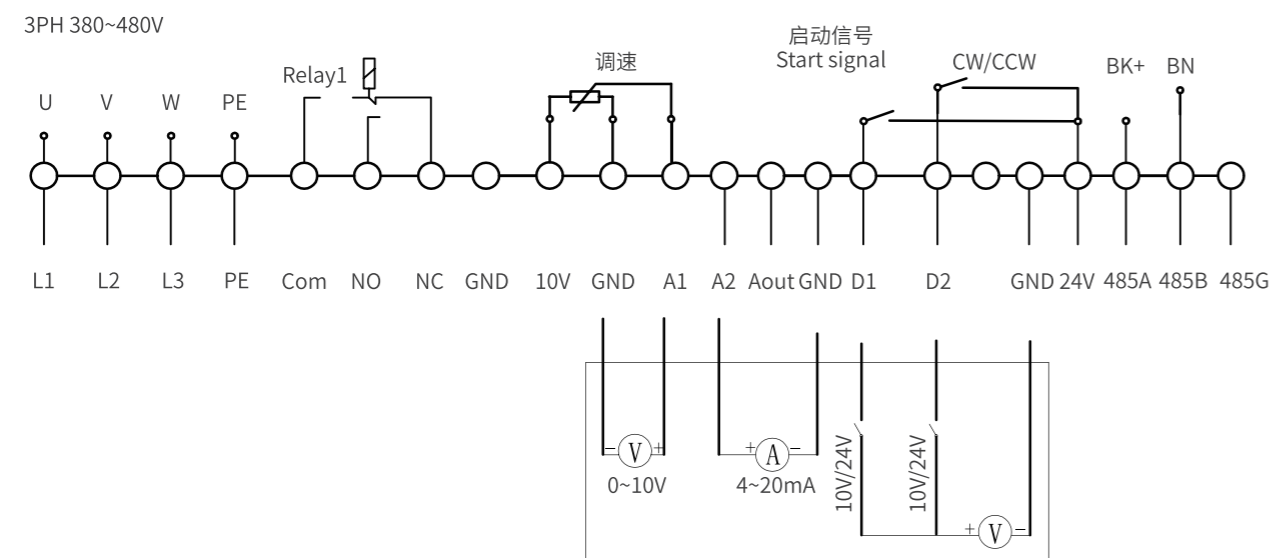

FAN CHECK LIST

风机选型

客户名称 Client name	
项目名称 Project name	
项目时间 Project duration	
预计年用量 Estimated annual usage	
期望价格 Desired price	
项目时间节点 Project timeline	
参考的产品描述 Referenced product description	
风机类型 Fan type	<input type="checkbox"/> 轴流 Axial <input type="checkbox"/> 离心 Centrifugal <input type="checkbox"/> 其他 Other
电机类型 Motor type	<input type="checkbox"/> 外转子 External rotor <input type="checkbox"/> 内转子 Internal rotor
电源类型 Power type	<input type="checkbox"/> 3-phase, 200-240V, 50/60Hz <input type="checkbox"/> 3-phase, 380-480V, 50/60Hz <input type="checkbox"/> 1-phase, 200-480V, 50/60Hz <input type="checkbox"/> 1-phase, 115V, 50/60Hz <input type="checkbox"/> 其他 Other
性能要求 Performance requirements	
风量 Air volume (m3/h)	
静压 Static pressure (Pa)	
叶轮直径 Impeller diameter: (mm)	
噪音 Lp(A) (dB(A))	
调速方式 Speed mode	
应用行业 Application industry	<input type="checkbox"/> 空调制冷 Air conditioning refrigeration <input type="checkbox"/> 电力电子 Power Electronics <input type="checkbox"/> 新风净化 Fresh air purification <input type="checkbox"/> 新能源 New energy <input type="checkbox"/> 农业畜牧 Agriculture and livestock <input type="checkbox"/> 轨道交通 Rail transit <input type="checkbox"/> 其他 Other
安装方式 Installation method	
环境条件 (室内 / 外、温度、湿度、海拔、灰尘、盐雾、振动) Environmental conditions: (Indoor/Outdoor, Temperature, Humidity, Altitude, Dust, Salt Spray, Vibration)	
防护等级 Protection class	
风机安装方式 Fan installation method	
风向 (吹风、吸风) Wind direction (Blowing, Suction)	
接线盒或电缆引出线 Terminal box or cable outlet	
喷涂颜色 RAL Spray color RAL	
认证要求 Certification requirements (CE, UL, CCC, GOST...)	
其他特殊要求 Other special requirements	



微信官方公众号
Wechat official account



风机产品样册
Fan product sample book

卧龙电气驱动集团股份有限公司
WOLONG ELECTRIC GROUP LTD.

地址:浙江省绍兴市上虞区人民西路1801号

Add: No.1801 West Renmin RD,Shangyu District,Shaoxing City,
Zhejiang Province,P.R.China

Web: www.wolong.com.cn

若您需咨询样本相关内容,敬请关注卧龙电驱官方公众号,通过菜单栏“联系我们”找到“咨询客服”,卧龙专家在线为您提供服务。

If you are interested in any related information,please subscribe Wolong Electric official Wechat account.Please access Customer Service in the WeChat menue.Wolong Experts will provide online consultancy services for you.